



**ILLUSTRATED PARTS LIST
LISTE DES PIECES
STÜCK LISTE**

KUBOTA

**MODEL
MODELE EA300-ENB1-1
MODELL**

**DIESEL ENGINE
MOTEUR DIESEL
DIESEL MOTOREN**

NOTICE

This Parts List is for the following purposes.

1. When ordering parts, check with this Parts List to confirm the part number and the name of parts.
2. When making repairs, refer to the illustrations in this Parts List.
3. This Parts List is subject to change without notice.

NOTE

Utilisation de ce livre

1. A la commande d'une pièce, chercher la référence et le nom de la pièce.
2. Pour les réparations, employez les illustrations.
3. La liste des pièces peut-être modifiée sans préavis.

ACHTUNG

Die vorliegende Stückliste ist zur Verwendung der folgenden Fälle aufzubewahren:

1. Bei Bestellung der Teile anhand dieser Liste die Kennzahl und die Bezeichnung der Teile feststellen.
2. Bei Reparatur auf die Figur in der Stückliste Bezug nehmen.
3. Änderungen dieser Bestandteilliste vorbehalten.

MODEL MODELE MODELL	CODE No. No. DE CODE CODE-Nr.
EA300-ENB1-1	1G110-00000

INSTRUCTIONS INSTRUCTION ERKLÄRUNG

①
0102 PISTON AND CRANKSHAFT
 PISTON ET VILEBREQUIN
 KOLBEN UND KURBELWELLE

⑪
 [B]
 ②
B02-R

⑩ → S.No. ; A: ≤15000, B: 14000 to 15000

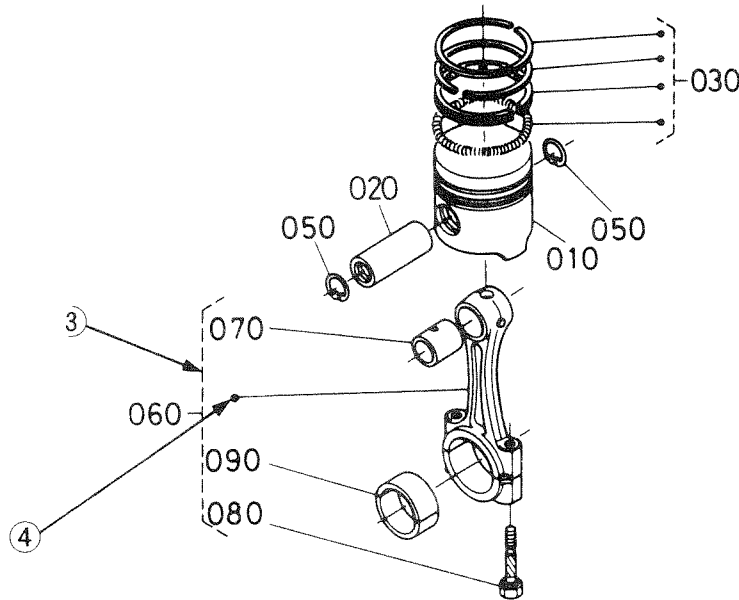



REF No POS No BILD-Nr	PART No. REFERENCE BESTELL-Nr.	PART NAME	DESIGNATION	BEZEICHNUNG	QTY/S No QTE/No S STUECK/S Nr		I.C	REMARKS REMARQUES BEMERKUNGEN
					A	B		
010	15800-0000-0	PISTON	PISTON	KOLBEN	1 ~15000	1 ~15000		[Example-1]
010	15800-0000-2	PISTON	PISTON	KOLBEN	1 15001~	1 15001~		[Exemple-1]
020	15800-1000-0	PIN,PISTON	AXE DE PISTON	KOLBENBOLZEN	1 ~15000	1 ~15000		[Beispiel-1]
020	15800-1000-2	PIN,PISTON	AXE DE PISTON	KOLBENBOLZEN	1 15001~	1 15001~		[Example-2]
030	15800-2000-0	ASSY PISTON RING	ENS.JEU DE SEGMENTS	KOLBENRINGE	1 ~15000	1 ~15000		[Exemple-2]
030	15830-2000-0	ASSY PISTON RING	ENS.JEU DE SEGMENTS	KOLBENRINGE	1 15001~	1 15001~		[Beispiel-2]
								[Example-3]
								[Exemple-3]
								[Beispiel-3]

A:XXXX, B:XXXX

- ① Fig. No. Represents No. corresponding to each group name.
- ② L. No. Substitute for conventional page numbering. Left-hand pages of the parts list are numbered in XXX-L, and the right-hand pages in XXX-R.
The location No. are also used in numerical index at the end of parts list.
- ③ Components The components of an assembly are identified by a bracket of dotted lines.
- ④ Point Indicates that the parts is not sold independently.
The assembly (Ref.No.060) containing the part needs to be ordered.
- ⑤ REF. No. Reference numbers are assigned to parts in the illustration. The code number of a part in the illustration can be identified by referring to the same reference number in the parts list.
- ⑥ Model name The name of the basic model is indicated in this column. Other applicable models are indicated on the "REMARKS" column ⑨.
- ⑦ S. No. Indicates a group of serial numbers to which a design change is applied.
(serial No.)
- ⑧ J. C. Indicates the interchangeability of parts due to design change.
(interchangeability)



Example-1  indicates that a new part can replace an old part, but not vice versa.
15800-0000-0 is applicable to the first serial number to S. No. 15000.
15800-0000-2 is applicable to the first serial number and above.



Example-2  indicates that the new and old parts are not interchangeable.
15800-1000-0 is applicable to the first serial number to S. No. 15000.
15800-1000-2 is applicable to S. No. 15001 and above.

Example-3  indicates that the new and old parts are interchangeable.
Both 15800-2000-0 and 15830-2000-0 are applicable to the first serial number and above.

- ⑨ REMARKS 1 In this column, enter other applicable model names, dimensions and other special items.
The following symbols and abbreviations are used throughout this book.
29*12.00-15 Tire size
sq.m m² sq.mm mm²
cu.m m³ cu.mm mm³
D Diameter L Length

- ⑩ REMARKS 2 The following expressions are used in NOTE for each group.
Machines' serial numbers are indicated as follows.
<=15000 Serial number below 15000.
>=15001 Serial number above 15001.
14000 to 15000 Serial number 14000 to 15000.
For some models, the above expressions may also be used REMARKS 1 ⑨.
- ⑪ Specifications The types and destinations of sister models are indicated. These indications are given to tell their relevant pages in this book.
(for sister models)

- ① No. de Fig Représente le No. de chaque nom de groupe.
- ② No.d'emplacement ... Représente le substitut du numérotage de page ordinaire. Les pages du côté gauche de la liste des pièces détachées sont numérotées en **XXX-L**.
Celles du côté droit sont numérotées en **XXX-R**. Les No. d'emplacement sont également utilisés dans l'index numérique à la fin de la liste des pièces détachées.
- ③ Composantes Les composantes d'un ensemble sont identifiées par des parenthèses en pointillé.
- ④ Point Indique que la pièce n'est pas à vendre toute seule.
Elle doit être commandée avec l'ensemble (POS.No. 060) qui la contient.
- ⑤ POS.No. Des numéros de position sont donnés aux pièces représentées dans l'illustration.
Le référence d'une pièce de l'illustration peut être identifié en se reportant au même numéro de position indiqué dans la liste des pièces détachées.
- ⑥ Nom de type Le nom du type de base est indiqué dans cette colonne. Les autres modèles sont indiqués dans la colonne des "REMARQUES" ⑨.
- ⑦ No. S. Indique un groupe de numéros de série qui a subit des modifications de modèle.
(No. de série)
- ⑧ I. C. Indique la permutabilité des pièces due à un changement dans le modèle.
(permutabilité)
- Exemple-1  indique que la nouvelle pièce peut remplacer la vieille, mais pas vice versa.
Le 15800-0000-0 s'applique au premier numéro de série jusqu'au No.S. 15000.
Le 15800-0000-2 s'applique au premier numéro de série et à ceux ci-dessus.
- Exemple-2  indique que la nouvelle et vieille pièces sont permutables.
Le 15800-1000-0 s'applique au premier numéro de série jusqu'au No.S. 15000.
Le 15800-1000-2 s'applique au No.S. 15001 et à ceuxci-dessus.
- Exemple-3  indique que la nouvelle piése et la vielle pièce sont interchangeable. Toules deux numéros 15800-2000-0 et 15830-2000-0 sont applicables a premier numéro de cette depuis.
- ⑨ REMARQUES 1 ... Cette colonne renferme d'autres noms de modèles applicables, les dimensions et autres éléments spéciaux.
Les symboles abrégés suivants sont utilisés dans l'ensemble de ce manuel.
29*12.00-15 Dimension des pneus
sq.m m² sq.mm mm²
cu.m m³ cu.mm mm³
D Diamètre L Longueur
- ⑩ REMARQUES 2 ... Les expressions suivantes sont utilisées dans la NOTE de chaque groupe.
Les numéros de série des machines sont indiqués de la manière suivante.
<=15000 Numéros de série au-dessous de 15000.
>=15001 Numéros de série au-dessus de 15001.
14000 to 15000 Numéros de série 14000 à 15000.
Pour certaines modèles, les expressions ci-dessus peuvent aussi être utilisées dans la rubrique des REMARQUES 1 ⑨.
- ⑪ Spécifications Les types et les destinations des modèles soeurs sont indiqués. Ces indications
(pour modèles soeurs) sont données pour donner leurs pages relatives dans ce livre.

- ① Abb. Nr. Diese Nummer bezieht sich auf die jeweilige Gruppenbezeichnung.
- ② Such-Nr. Diese Nummer ersetzt die Seitenzahl. Die linken Seiten der Ersatzteilliste tragen die Nummern XXX-L, die rechten Seiten die Nummern XXX-R.
Die Such-Nr. wird ebenfalls im numerischen Index am Ende der Ersatzteilliste aufgeführt.
- ③ Einzelteile Die Einzelteile einer Baugruppe sind durch eine Klammer aus gestrichelten Linien gekennzeichnet.
- ④ Punkte Punktierung zeigt an, daß das entsprechende Teil nicht einzeln erhältlich ist. Die gesammte Baugruppe, die dieses Teil beinhaltet muß bestellt werden. (BILD-Nr. 060).
- ⑤ BILD-Nr. Die Teile in den Abbildungen sind mit Bezugsnummern versehen. Die Kennnummer eines der abgebildeten Teile erhalten Sie, wenn Sie unter der Bezugsnummer in der Ersatzteilliste nachsehen.
- ⑥ Typenbezeichnung ... In dieser Spalte wird die Bezeichnung des Grundtype aufgeführt. Weiter Modelle, die verwendet werden können werden unter "BEMERKUNGEN" in Spalte ⑨ angegeben.
- ⑦ S. Nr. Bezeichnet eine Gruppe Seriennummern, bei der Änderungen in der Ausführung (Serien Nr.) vorgenommen wurden.
- ⑧ I. C. Bezeichnet die Austauschmöglichkeit der Teile untereinander bei einer Änderung in der Ausführung. (Austauschmöglichkeit)
- Beispiel- 1  besagt, daß das alte Teil durch ein neues ersetzt werden kann, nicht jedoch umgekehrt. 15800-0000-0 bezieht sich auf die erste Serien Nr. bis S.Nr. 15000. 15800-0000-2 bezieht sich auf die erste Serien Nr. und darüber.
- Beispiel- 2  besagt, daß alte und neue Teile nicht austauschbar sind. 15800-1000-0 bezieht sich auf die erste Serien Nr. bis S.Nr. 15000. 15800-1000-2 bezieht sich auf S.Nr. 15001 und darüber.
- Beispiel- 3  besagt, daß alte und neue Teile austauschbar sind. Beiderseitig 15800-2000-0 und 15830-2000-0 bezieht sich auf die erste Serien Nr. und darüber.
- ⑨ BEMERKUNGEN 1 ... In dieser Spalte finden Sie weitere verwendbare Modellbezeichnungen, Abmessungen und andere besondere Angaben.
Die folgenden Symbole und Abkürzungen werden im Gesamtext des Buches benutzt :
- 29 * 12.00-15 Reifengrößen
sq.m m² sq.mm mm²
cu.m m³ cu.mm mm³
D Durchmesser L Länge
- ⑩ BEMERKUNGEN 2 ... Die folgenden Ausdrücke werden in "NOTE" für jede Gruppe verwendet.
Seriennummern von Maschinen werden wie folgt angezeigt :
- <=15000 ... Seriennummern unter 15000.
>= Seriennummern über 15001.
14000 bis 15000 Seriennummern 14000 bis 15000.
Bei einigen Modellen können die oben genannten Ausdrücke auch in "ANMERKUNGEN 1 9)" verwendet werden.
- ⑪ Spezifikationen Die Typen und Bestimmungsorte der Schwestermodelle sind angegeben. Die (für Schwestermodelle) Angaben beziehen sich auf die entsprechenden Seiten in diesem Handbuch.

CONTENTS

[EA300-ENB1-1]

0001	CRANKCASE.....	B01-L
0003	CYLINDER HEAD.....	B01-R
0004	GEAR CASE.....	B02-L
0005	HEAD COVER.....	B02-R
0006	OIL FILTER.....	B03-L
0007	DIPSTICK AND GUIDE.....	B03-R
0008	OIL PUMP.....	B04-L
0009	SIDE APRON AND START HANDLE.....	B04-R
0100	MAIN BEARING CASE.....	B05-L
0101	CAMSHAFT AND IDLE GEAR SHAFT.....	B05-R
0102	PISTON AND CRANKSHAFT.....	B06-L
0103	FLYWHEEL.....	B06-R
0106	BALANCER.....	B07-L
0200	IDLE APPARATUS.....	B07-R
0202	INJECTION PUMP.....	B08-L
0203	INJECTION PUMP (COMPONENT PARTS).....	B08-R
0204	GOVERNOR.....	B09-L
0205	SPEED CONTROL PLATE.....	B09-R
0206	NOZZLE HOLDER AND GLOW PLUG.....	B10-L
0207	NOZZLE HOLDER (COMPONENT PARTS).....	B10-R
0300	FUEL FILTER.....	B11-R
0304	FUEL TANK.....	B12-L
0404	STARTER.....	B12-R
0405	STARTER (COMPONENT PARTS).....	B13-L
0406	OIL SWITCH/THERMOMETER AND PLUG.....	B13-R
0502	RADIATOR.....	B14-L
0504	FAN.....	B14-R
0506	TENSION PULLEY.....	B15-L
0600	VALVE AND ROCKER ARM.....	B15-R
0603	AIR CLEANER.....	B16-L
0605	MUFFLER.....	B16-R
0800	GLOW LAMP AND TIMER.....	C01-L
0802	CONTROL BOX AND METER.....	C01-R
0808	ACCESSORIES AND SERVICE PARTS.....	C02-L
0809	LABEL AND OPERATOR'S MANUAL.....	C02-R
■	NUMERICAL INDEX.....	D01-L

SOMMAIRE

[EA300-ENB1-1]

0001	BLOC MOTEUR.....	B01-L
0003	CULASSE.....	B01-R
0004	CARTER DE DISTRIBUTION.....	B02-L
0005	COUVRE-CULASSE.....	B02-R
0006	FILTRE D'HUILE.....	B03-L
0007	JAUGE D'HUILE ET GUIDE.....	B03-R
0008	POMPE D'HUILE.....	B04-L
0009	TABLIER ET POIGNEE DEMARRAGE.....	B04-R
0100	PALIERS DE VILEBREQUIN.....	B05-L
0101	ARBRE A GAMES ET ARBRE DE PIGNON FOU.....	B05-R
0102	PISTON ET VILEBREQUIN.....	B06-L
0103	VOLANT MOTEUR.....	B06-R
0106	COMPENSATEUR.....	B07-L
0200	DISPOSITIF DE RALENTISSEUR.....	B07-R
0202	POMPE D'INJECTION.....	B08-L
0203	POMPE D'INJECTION (PARTIES COMPOSANTES).....	B08-R
0204	REGULATEUR DE VITESSES.....	B09-L
0205	PLAQUE DE VITESSE-CONTROLE.....	B09-R
0206	PORTE-INJECTEUR ET BOUGIE DE PRECHAUFFAGE.....	B10-L
0207	PORTE-INJECTEUR (PARTIES COMPOSANTES).....	B10-R
0300	FILTRE A CARBURANT.....	B11-R
0304	RESERVOIR A CARBURANT.....	B12-L
0404	DEMARREUR.....	B12-R
0405	DEMARREUR (PARTIES COMPOSANTES).....	B13-L
0406	CONTACT A HUILE /THERMOMETRE ET OBTURATEUR.....	B13-R
0502	RADIATEUR.....	B14-L
0504	VENTILATEUR.....	B14-R
0506	POULIE DE TENSION.....	B15-L
0600	SOUAPES ET CULBUTEURS.....	B15-R
0603	FILTRE A AIR.....	B16-L
0605	SILENCIEUX.....	B16-R
0800	INDICATEUR DE PRECHAUFFAGE ET TEMPORISATEUR.....	C01-L
0802	BOITE DE CONTROLE ET COMPTEUR.....	C01-R
0808	ACCESSOIRES ET PIECES DE SERVICE.....	C02-L
0809	ETIQUETTE ET MANUEL DE L'UTILISATEUR.....	C02-R
■	INDEX NUMERIQUE.....	D01-L

INHALTSVERZEICHNIS

[EA300-ENB1-1]

0001	KURBELGEHAEUSE	B01-L
0003	ZYLINDERKOPF	B01-R
0004	GETRIEBEGEHAEUSE	B02-L
0005	ZYLINDERKOPF-DECKEL	B02-R
0006	OELFILTER	B03-L
0007	OELMESSSTAB UND FUEHRUNG	B03-R
0008	OEL PUMPE	B04-L
0009	ROLLBODEN UND HANDGRIFF	B04-R
0100	HAUPTLAGERGEHAEUSE	B05-L
0101	NOCKENWELLE UND FREILAUFGETRIEBEWELLE	B05-R
0102	KOLBEN UND KURBELWELLE	B06-L
0103	SCHWUNGRAD	B06-R
0106	MASSENNAUSGLEICH	B07-L
0200	FREILAUFAPPARAT	B07-R
0202	EINSPRITZENPUMPE	B08-L
0203	EINSPRITZENPUMPE (EINZEL-TEIL)	B08-R
0204	REGLER	B09-L
0205	GESCHWINDIGKEITS-REGLERPLATTE	B09-R
0206	DUESENHALTER UND GLUEHKERZE	B10-L
0207	DUESENHALTER (EINZEL-TEIL)	B10-R
0300	KRAFTSTOFFILTER	B11-R
0304	KRAFTSTOFFBEHAELTER	B12-L
0404	ANLASSER	B12-R
0405	ANLASSER (EINZEL-TEIL)	B13-L
0406	OELSCHALTER/THERMOMETER UND VERSCHLUSSSTOPFEN	B13-R
0502	KUEHLER	B14-L
0504	VENTILATOR	B14-R
0506	SPANENNROLLE	B15-L
0600	VENTIL UND KIPPENARM	B15-R
0603	LUFTREINHEIT	B16-L
0605	AUSPUFFTOPF	B16-R
0800	GLUEHLAMPE UND ZEITMESSER	C01-L
0802	STEUERGEHAUSE UND MESSGERAT	C01-R
0808	ZUBEHOER UND BEDIENUNG-TEIL	C02-L
0809	ETIKETTE UND HANDHABUNG-GEBRAUCHSANWEISUNG	C02-R
■	NUMERISCHEN INDEX	D01-L

0009

SIDE APRON AND START HANDLE
 TABLIER ET POIGNEE DEMARRAGE
 ROLLBODEN UND HANDGRIFF

B04-R

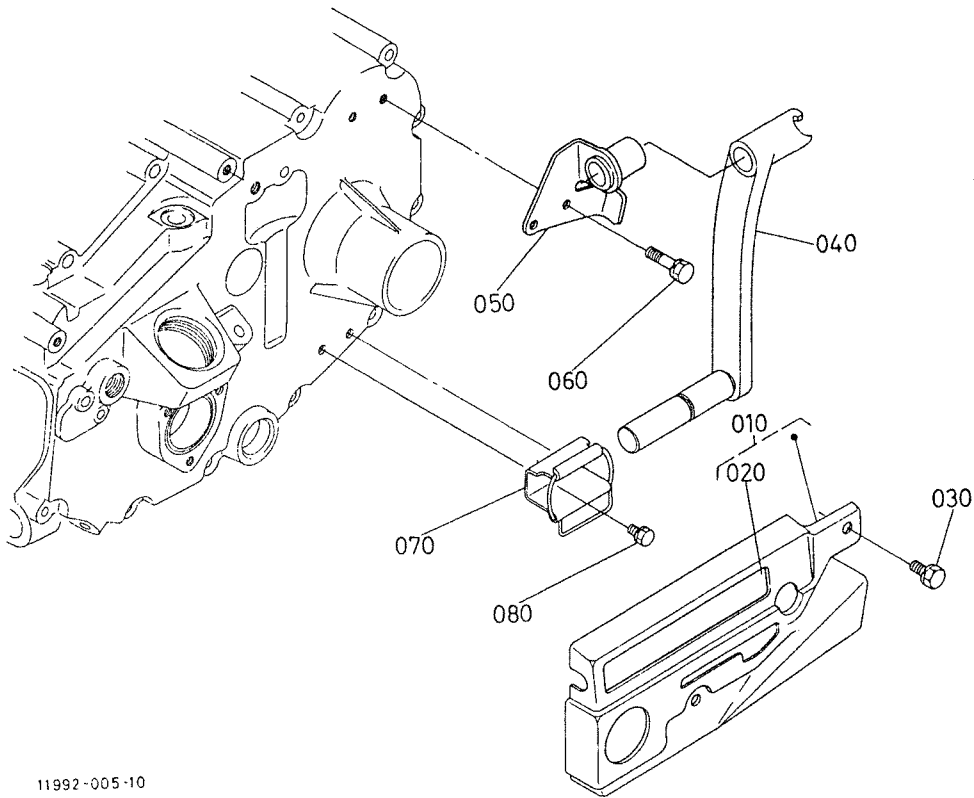

11992-005-10

A:EA300-ENB1-1

REF.No. POS.No. BILD-Nr.	PART No. REFERENCE BESTELL-Nr.	PART NAME	DESIGNATION	BEZEICHNUNG	Q'TY/S. No. Q'TE/No. S. STUECK/S. Nr.	I.C.	REMARKS REMARQUES BEMERKUNGEN
010	1G111-0480-0	COMP APRON, SIDE	TABLIER, COMP	ROLLBODEN	1		
020	1G111-8855-0	LABEL, SPEED	ETIQUETTE	AUFKLEBER	1		
030	01023-50612	BOLT	VIS	BOLZEN	2		
040	19104-6111-2	HANDLE, START	POIGNEE DEMARRAGE	HANDGRIFF	1		
050	14971-6128-4	SUPPORT, START HANDLE	SUPPORT POIGNEE DEM.	STUTZE	1		
060	01023-50616	BOLT	VIS	BOLZEN	2		
070	11982-6122-0	HOLDER, START HANDLE	SUPPORT POIGNEE DEM.	HALTER	1		
080	01202-50612	BOLT	VIS	BOLZEN	2		

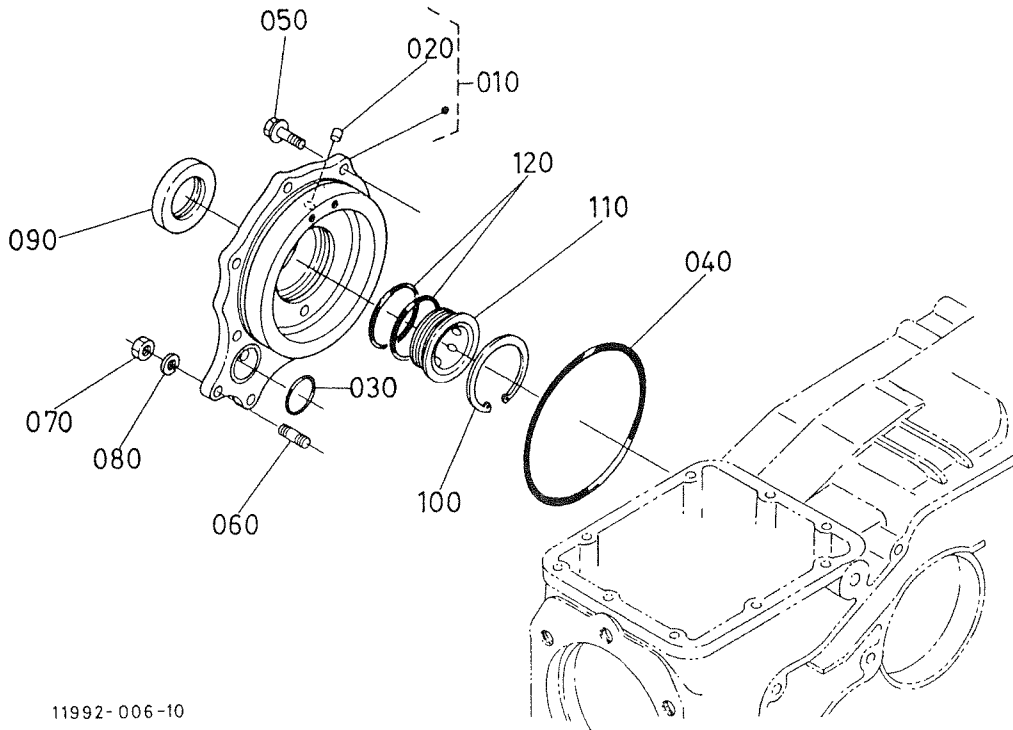

11992-006-10

A:EA300-ENB1-1

REF.No. POS.No. BILD-Nr	PART No. REFERENCE BESTELL-Nr.	PART NAME	DESIGNATION	BEZEICHNUNG	Q' TY/S. No. Q' TE/No. S. STUECK/S. Nr.	I. C.	REMARKS REMARQUES BEMERKUNGEN
010	14981-0404-2	COMP. BEARING CASE	ENS. CARTER DE BAGUE	BAUGRP. HPT. LAGERGEH	1		
020	14541-9685-0	PLUG	BOUCHON	STOPFEN	1		
030	14911-3545-0	O RING	JOINT TORIQUE	O RING	1		
040	04811-11050	O RING	JOINT TORIQUE	O RING	1		
050	01754-50620	BOLT, FLANGE	VIS DE BUTEE	FLANSCHEN-BOLZEN	7		
060	01518-50620	STUD	GOIJON	STEBBOLZEN	2		
070	02056-50060	NUT	ECROU	MUTTER	2		
080	04512-60060	WASHER, SPRING	RONDELLE GROWER	FEDERRING	2		
090	14971-2355-0	SEAL, OIL	BAGUE JOINT	OELDICHTUNGSRING	1		
100	04611-00500	CIR CLIP, INTERNAL	CIRCLIP	SPRENGRING	1		
110	14971-3575-0	RING	BAGUE	RING	1		
120	14971-3577-0	O RING	JOINT TORIQUE	O RING	2		

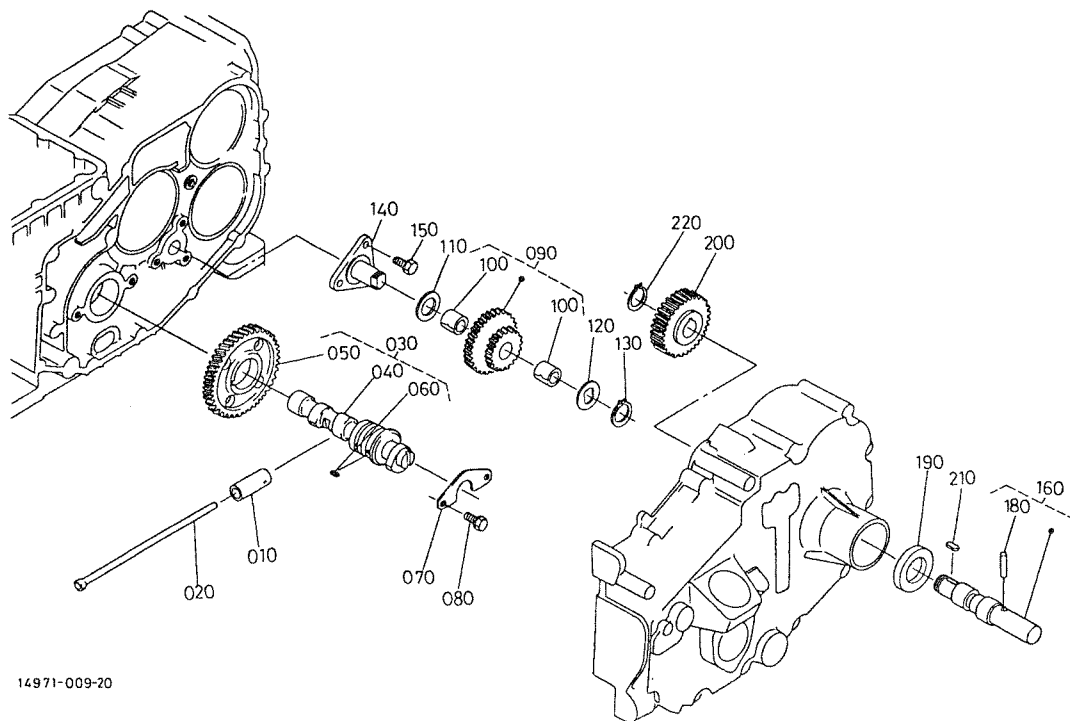

14971-009-20

A:EA300-ENB1-1

REF.No. POS.No. BILD-Nr	PART No. REFERENCE BESTELL-Nr.	PART NAME	DESIGNATION	BEZEICHNUNG	Q' TY/S.No. Q' TE/No. S. STUECK/S. Nr.	I.C.	REMARKS REMARQUES BEMERKUNGEN
					A		
010	16261-1555-0	TAPPET	POUSSOIR	STOSSEL	2		
020	14971-1511-0	PUSH ROD	TIGE DE POUSSOIR	STOSSELSTANGE	2		
030	14971-1601-0	ASSY CAMSHAFT	ENS. ARBRE A CAMES	GRP. NOCKENWELLE	1		
040	14971-1615-0	CAMSHAFT	ARBRE A CAMES	NOCKENWELLE	1		
050	14971-1651-0	GEAR, CAM	PIGNON	ZAHNRAD	1		
060	15271-1624-0	KEY, FEATHER	CLAVETTE	KEIL	1		
070	14971-1627-0	STOPPER, CAMSHAFT	BOUCHON ARBRE A CAME	NOCKENWELLESPIERRPLA.	1		
080	01023-50616	BOLT	VIS	BOLZEN	2		
090	14971-2401-0	COMP. GEAR, IDLE	PIGNON FOU COMP.	KOMP. LEERLAUFGETRIEB	1		
100	15261-2498-0	BUSH, IDLE GEAR	BAGUE DU PIGNON	BUCHSE, LEERLAUFGETR.	2		
110	15261-2436-0	COLLAR, IDLE GEAR	COLLIER PIGNON FOU	HALSRING	1		
120	15261-2437-0	COLLAR, IDLE GEAR	COLLIER PIGNON FOU	HALSRING	1		
130	15261-2432-0	STOPPER, IDLE GEAR	BRIDE, PIGNON FOU.	SPERRPLATTE	1		
140	14971-2425-0	SHAFT, IDLE GEAR	ARBRE DE PIGNON FOU	WELLE, FREILAUFGETR.	1		
150	01023-50616	BOLT	VIS	BOLZEN	3		
160	11151-6220-0	SHAFT, START	ARBRE DEMARRAGE	WELLE	1		
170	----	BLANK	BLANC	LEERE SPALTE	-		
180	14107-6227-0	PIN, START SHAFT	GOUPILLE	STIFT	1		
190	09550-25357	SEAL, OIL	BAGUE JOINT	OELDICHTUNGSRING	1		
200	14971-6212-0	GEAR, START	ENGR. DE DEPART	GETRIEBE	1		
210	05712-00510	KEY, FEATHER	CLAVETTE	KEIL	1		
220	04612-00160	CIR CLIP, EXTERNAL	CIRCLIP	SPRENGRING, AUSSEN	1		

0102

 PISTON AND CRANKSHAFT
 PISTON ET VILEBREQUIN
 KOLBEN UND KURBELWELLE

B06-L

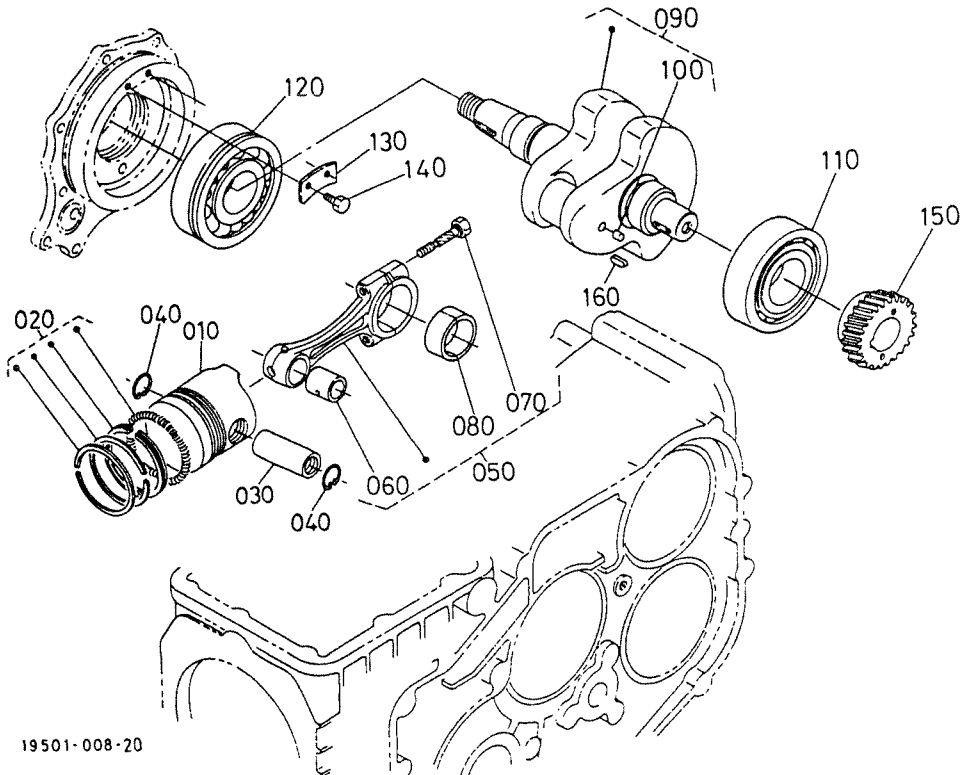

19501-008-20

A:EA300-ENB1-1

REF.No. POS.No. BILD-Nr	PART No. REFERENCE BESTELL-Nr.	PART NAME	DESIGNATION	BEZEICHNUNG	Q' TY/S. No. Q' TE/No. S. STUECK/S. Nr.	I. C.	REMARKS REMARQUES BEMERKUNGEN
					A		
010	15532-2111-0	PISTON	PISTON	KOLBEN	1		STD
010	15531-2191-0	PISTON	PISTON	KOLBEN	1		+0.5mm
020	15531-2105-0	ASSY PISTON RING	ENS. SEGMENT	GRP. KOLBENRING	1		STD
020	15531-2109-0	ASSY PISTON RING	ENS. SEGMENT	GRP. KOLBENRING	1		+0.5mm
030	15261-2131-0	PIN, PISTON	AXE DE PISTON	KOLBENBOLZEN	1		
040	15261-2133-0	CIR CLIP, PISTON PIN	CIRCLIP	SEEGERING	2		
050	15694-2201-0	ASSY CONNECTING ROD	ENS. BIELLE	GRP. PLEUELSTANGE	1		
060	15261-2198-0	BUSH, PISTON PIN	BAGUE DE BIELLE	BUCHSE, KOLBENSTIFT	1		
070	15381-2214-0	BOLT, CONNECTING ROD	VIS DE BIELLE	BOLZEN	2		
080	15694-2231-0	METAL, CRANKPIN	COUSSINET DE BIELLE	METALLTEIL	1		STD SET
080	15694-2297-0	METAL, CRANKPIN	COUSSINET DE BIELLE	METALLTEIL	1		-0.2mm SET
080	15694-2298-0	METAL, CRANKPIN	COUSSINET DE BIELLE	METALLTEIL	1		-0.4mm SET
090	14971-2301-2	COMP. CRANKSHAFT	VILEBREQUIN COMPLET	KOMP. KURBELWELLE	1		
100	14941-2324-0	PLUG	BOUCHON	STOPFEN	1		
110	14971-2345-0	BEARING, MAIN	ROULEMENT PRINC.	KUGELLAGER	1		
120	14981-2346-0	BEARING, MAIN	ROULEMENT PRINC.	KUGELLAGER	1		
130	14971-2359-0	STOPPER	POINTEAU D'ARRET	STOPFEN	1		
140	01053-50512	BOLT	VIS	BOLZEN	2		
150	14971-2411-0	GEAR, CRANK	PIGNON	ZAHNRAD	1		
160	05712-00515	KEY, FEATHER	CLAVETTE	KEIL	1		

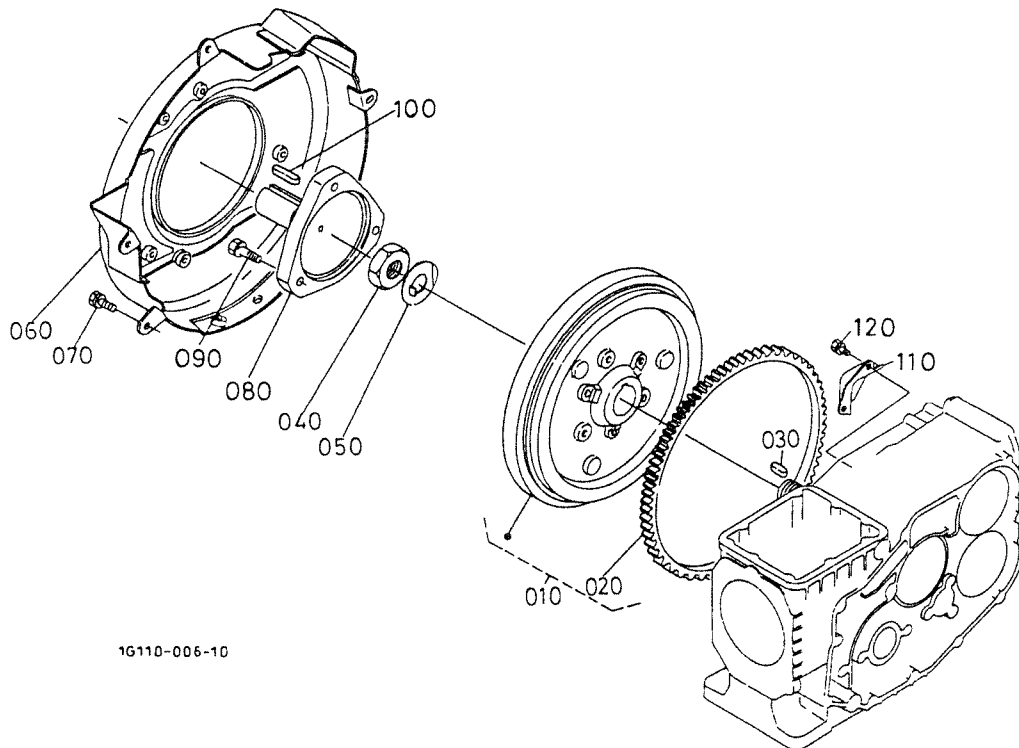

1G110-006-10

A:EA300-ENB1-1

REF.No. POS.No. BILD-Nr.	PART No. REFERENCE BESTELL-Nr.	PART NAME	DESIGNATION	BEZEICHNUNG	Q' TY/S. No. Q' TE/No. S. STUECK/S. Nr.	I.C.	REMARKS REMARQUES BEMERKUNGEN
					A		
010	14278-2501-7	COMP. FLYWHEEL	VOLANT MOTEUR COMP.	KOMP. SCHWUNGRAD	1		
020	16261-6382-2	GEAR, RING	COURONNE DE DEMARRE.	ZAHNKRANZ	1		
030	14971-9501-2	KEY, FEATHER	CLAVETTE	KEIL	1		
040	14971-2336-0	NUT, CRANKSHAFT	ECROU DE VILEB.	MUTTER, KURBELWELLE	1		
050	14971-2337-2	WASHER, FLYWHEEL	RONDELLE VOLANT MOT.	SCHEIBE, SCHWUNGRAD	1		
060	14279-2533-5	COVER, FLYWHEEL	COUVERCLE DE VOLANT	SCHWUNGRADDECKEL	1		
070	01023-50614	BOLT	VIS	BOLZEN	4		
080	19501-8451-0	SHAFT, PULLEY	ARBRE DE POULIE	WELLE	1		
090	01123-50830	BOLT	VIS	BOLZEN	3		
100	19142-9501-0	KEY, FEATHER	CLAVETTE	KEIL	1		
110	14971-2531-2	COVER, FLYWHEEL	COUVERCLE DE VOLANT	SCHWUNGRADDECKEL	1		
120	01023-50612	BOLT	VIS	BOLZEN	2		

0106

BALANCER
 COMPENSATEUR
 MASSENNAUSGLEICH

B07-L

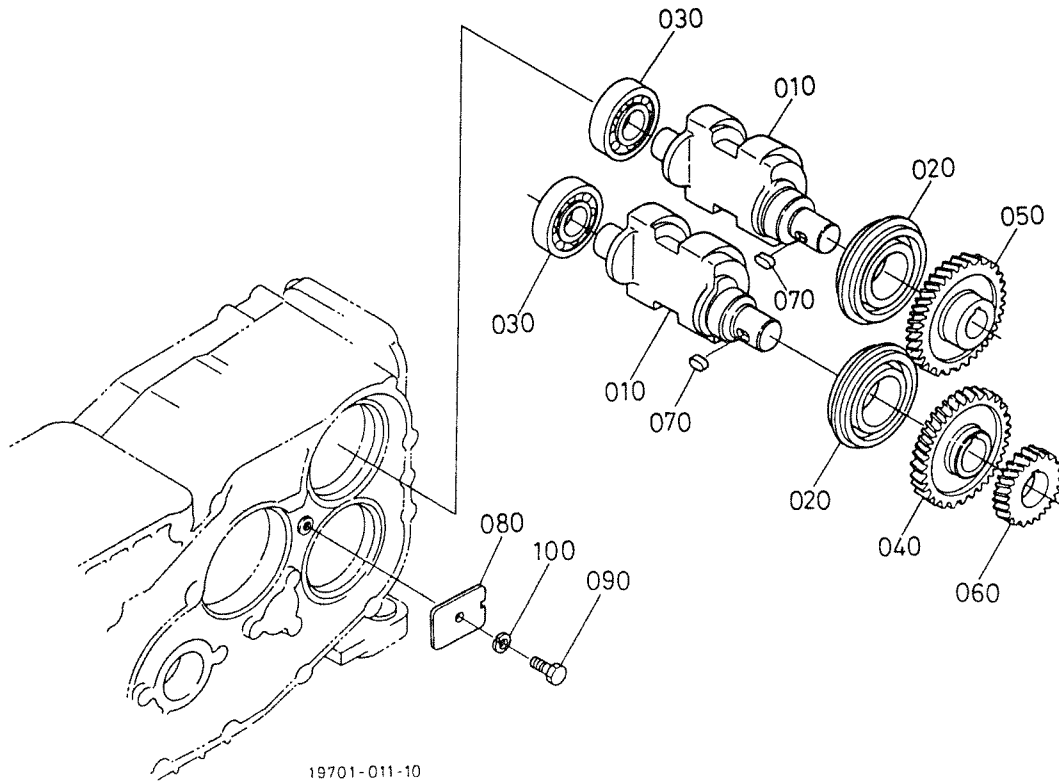

19701-011-10

A:EA300-ENB1-1

REF.No. POS.No. BILD-Nr	PART No. REFERENCE BESTELL-Nr.	PART NAME	DESIGNATION	BEZEICHNUNG	Q' TY/S. No.	I.C.	REMARKS REMARQUES BEMERKUNGEN
					Q' TE/No. S. STUECK/S. Nr.		
					A		
010	14971-2625-0	BALANCER	BILAN	BILANZ	2		
020	14971-2628-0	BEARING, BALANCER	ROULEMENT	KUGELLAGER	2		
030	14911-2629-0	BEARING, BALANCER	ROULEMENT	KUGELLAGER	2		
040	14971-2644-0	GEAR, BALANCER	PIGNON DE BALANCIER	GETRIEBE, SCHWINGE	1		
050	14971-2645-0	GEAR, BALANCER	PIGNON DE BALANCIER	GETRIEBE, SCHWINGE	1		
060	14971-2646-0	GEAR, BALANCER	PIGNON DE BALANCIER	GETRIEBE, SCHWINGE	1		
070	05712-00518	KEY, FEATHER	CLAVETTE	KEIL	2		
080	14971-2681-0	RETAINER, BEARING	SUPPORT DE ROULEMENT	ARRETIERUNG	1		
090	01053-50614	BOLT	VIS	BOLZEN	1		
100	04512-60060	WASHER, SPRING	RONDELLE GROWER	FEDERRING	1		

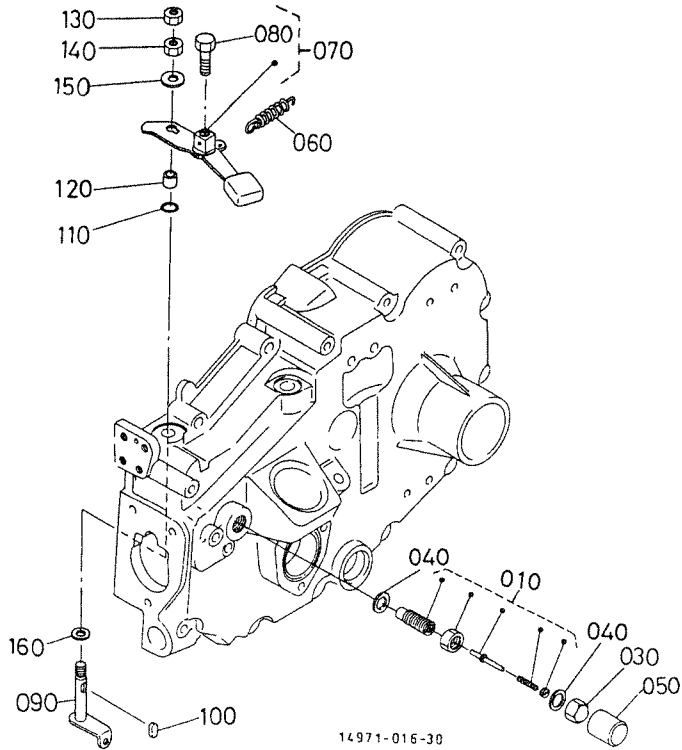

14971-016-30

A:EA300-ENB1-1

REF.No POS.No BILD-Nr	PART No. REFERENCE BESTELL-Nr.	PART NAME	DESIGNATION	BEZEICHNUNG	Q'TY/S. No. Q'TE/No. S. STUECK/S. Nr.	I.C.	REMARKS REMARQUES BEMERKUNGEN
010	1G111-5402-0	APPARATUS, FUEL LIMIT	AP. LIM. CARBURANT	ANLAGE, KRAFTSTOFF	A 1		
020	----	BLANK	BLANC	LEERE SPALTE	-		
030	15261-5422-0	NUT	ECROU	MUTTER	1		
040	15109-3366-0	GASKET	JOINT	DICHTUNGSPLATTE	2		
050	1G121-5429-0	PIPE	TUYAU	ROHR	1		
060	14972-5654-0	SPRING, STOP	RESSORT, ARRET	SICHERUNGSRING	1		
070	14971-5704-0	ASSY LEVER, SP/CONT	ENS. LEVIER	WENDEVORRICHTUNG	1		
080	01222-50610	BOLT	VIS	BOLZEN	1		
090	14971-5723-0	COMP SHAFT, SP/CONT	ARBRE COMP	GRP. SCHAFTDREHZAHL.	1		
100	15261-9501-0	KEY, FEATHER	CLAVETTE	KEIL	1		
110	04811-00070	O RING	JOINT TORIQUE	O RING	1		
120	15263-5738-0	PLATE, FRICTION, NA	PLATEAU DE FRICTION	REIBUNGSPLATTE	1		
130	02012-60060	NUT	ECROU	MUTTER	1		
140	02056-50060	NUT	ECROU	MUTTER	1		
150	04013-60060	WASHER, PLAIN	RONDELLE FREIN	SCHEIBE	1		
160	04012-50080	WASHER, PLAIN	RONDELLE FREIN	SCHEIBE	1		

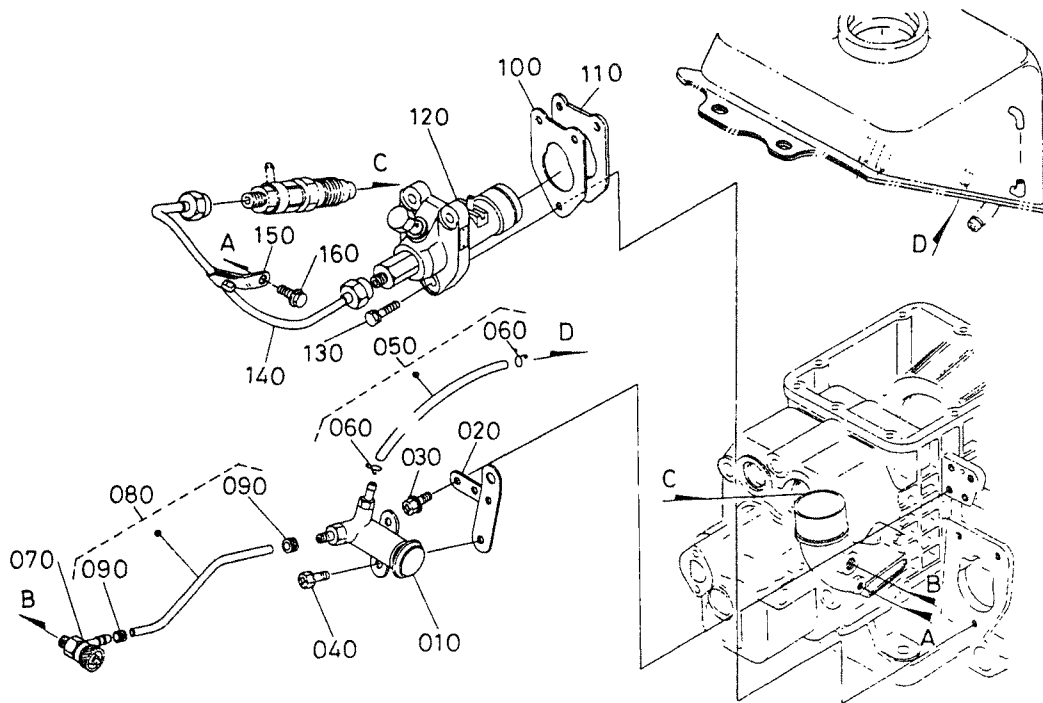

1G114-013-10

A: EA300-ENB1-1

REF.No. POS.No. BILD-Nr.	PART No. REFERENCE BESTELL-Nr.	PART NAME	DESIGNATION	BEZEICHNUNG	Q' TY/S. No. Q' TE/No. S. STUECK/S. Nr.	I.C.	REMARKS REMARQUES BEMERKUNGEN
					A		
010	14311-6070-0	ASSY JET-START	GICLEUR DE DEPART	GRP. STARTDUSE	1		
020	14971-4292-2	HOLDER, JETSTART	SUPPORT	INHABER	1		
030	01023-50616	BOLT	VIS	BOLZEN	2		
040	01023-50612	BOLT	VIS	BOLZEN	2		
050	14279-4287-0	ASSY PIPE, JET START	ENS. TUYAU GICLEUR	GRP. STARTDUESEROHR	1		
060	14971-4275-0	CLIP, PIPE	ATTACHE	ROHRKLEMME	2		
070	14311-6050-4	ASSY COCK, JET START	ROBINET DE PURGE	GRP. STARTDUESEHAHN	1		
080	14971-6090-0	ASSY PIPE, JET START	ENS. TUYAU GICLEUR	GRP. STARTDUESEROHR	1		
090	10101-4239-0	CLIP, PIPE	ATTACHE	ROHRKLEMME	2		
100	14971-5211-0	SHIM, PUMP ADJUST	CALE REGLAGE POMPE	JUSTIERSCHEIBE	4		0.15mm
100	1G111-5211-0	SHIM	CALE	BEILAGE	2		0.10mm
110	14971-5212-0	SHIM, PUMP ADJUST	CALE REGLAGE POMPE	JUSTIERSCHEIBE	1		0.50mm
120	1G111-5101-2	ASSY PUMP, INJECTION	ENS. POMPE INJECTION	GRP. EINSPRITZPUMPE	1		
130	01023-50622	BOLT	VIS	BOLZEN	3		
140	1G111-5371-2	PIPE, INJECTION	TUYAU D' INJECTEUR	EINSPRITZROHR	1		
150	14971-5385-2	CLAMP, PIPE	COLLIER DE TUYAU	ROHRKLEMME	1		
160	01754-50614	BOLT, FLANGE	VIS DE BUTEE	FLANSCHEN-BOLZEN	1		

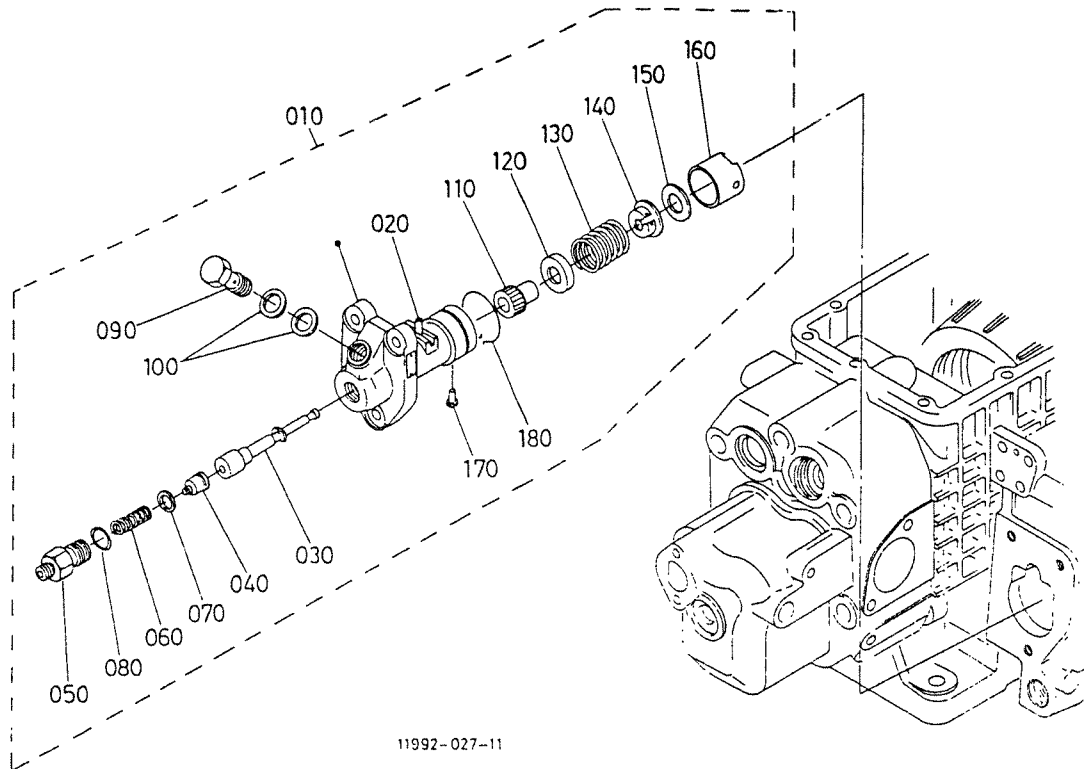

11992-027-11

A:EA300-ENB1-1

REF.No. POS.No. BILD-Nr.	PART No. REFERENCE BESTELL-Nr.	PART NAME	DESIGNATION	BEZEICHNUNG	Q' TY/S. No. Q' TE/No. S. STUECK/S. Nr.	I.C.	REMARKS REMARQUES BEMERKUNGEN
					A		
010	1G111-5101-2	ASSY PUMP, INJECTION	ENS. POMPE INJECTION	GRP. EINSPRITZPUMPE	1		
020	14911-5106-0	RACK, CONTROL	CREMAILLIERE DE LUTTE	STEUERUNGSTEIL	1		
030	14911-5105-0	PLUNGER, PUMP	PLONGEUR	PUMPENKOLBEN	1		
040	15221-5103-0	VALVE, DELIVERY	SOUPAPE DE REFOUL.	VENTIL	1		
050	15271-5122-0	HOLDER, DELIV. VALVE	SUPPORT	ENTLAST-VENTILHALTER	1		
060	15221-5123-0	SPRING, DELIV. VALVE	RESSORT SOUPAPE REF	FEDER	1		
070	15221-5124-0	GASKET, DELIV. VALVE	JOINT DE SOUPAPE	DICHTUNG, DRUCKVENTIL	1		
080	14611-5120-0	O RING	JOINT TORIQUE	O RING	1		
090	14911-5132-0	SCREW, FOLLOW	VIS	SCHRAUBE	1		
100	14107-5134-0	GASKET	JOINT	DICHTUNGSPLATTE	2		
110	15221-5138-2	SLEEVE, CONTROL	MANCHON DE COMMANDE	MUFFE	1		
120	15221-5127-0	SEAT, SPRING UPPER	SIEGE DE RESSORT	FEDERTELLER OBERE	1		
130	15221-5128-0	SPRING, PLUNGER	RESSORT DE PLONGEUR	KOLBENFEDER	1		
140	15221-5129-0	SEAT, SPRING LOWER	SIEGE DE RESSORT	FEDERTELLER UNTERE	1		
150	14109-5130-0	PLATE, SHIM	PLAQUE, CALE	AKKUMULATORPLATTE	1		
160	15221-5107-0	ASSY TAPPET	ENS. POUSSOIR	GRP. VENTILSTOESSEL	1		
170	15221-5125-0	PIN, TAPPET GUIDE	GOUPILLE	STOESSELFUHRUNGSTIFT	1		
180	14911-5143-0	PIN, CLAMP	CLAVETTE	STIFT	1		

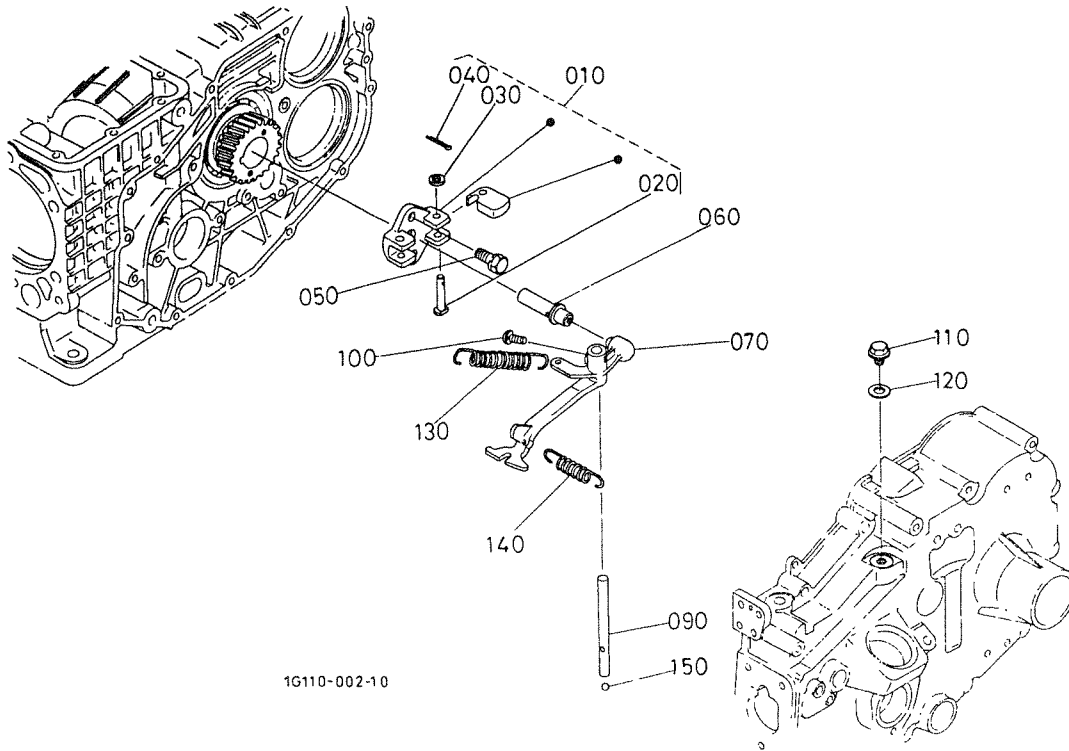

1G110-002-10

A:EA300-ENB1-1

REF.No. POS.No. BILD-Nr	PART No. REFERENCE BESTELL-Nr.	PART NAME	DESIGNATION	BEZEICHNUNG	Q' TY/S. No.	I.C.	REMARKS REMARQUES BEMERKUNGEN
					Q' TE/No. S. STUECK/S. Nr.		
010	14971-5505-2	ASSY WEIGHT, GOVERNOR	ENS. POIDS	FLIEHGEWICHT	1		
020	14911-5528-0	PIN, GOVERNOR WEIGHT	GOUP. POIDS REGUL.	STIFT	2		
030	04012-50060	WASHER, PLAIN	RONDELLE FREIN	SCHEIBE	2		
040	19090-1539-0	PIN, SPLIT	GOUPILLE FENDUE	SPLINTSTIFT	2		
050	01023-50614	BOLT	VIS	BOLZEN	2		
060	14911-5531-0	SHAFT, GOVERNOR	ARBRE DE REGULATEUR	REGLERWELLE	1		
070	14971-5604-0	COMP. LEVER, GOVERNOR	AXE D'ACCELERATEUR	KOMP. REGLERHEBEL	1		
080	----	BLANK	BLANC	LEERE SPALTE	-		
090	14971-5614-0	SHAFT, GOVERNOR LEVER	ARBRE DE LEVIER REG.	REGLERHEBELWELLE	1		
100	03024-50514	SCREW, WITH WASHER	VIS	SCHRAUBE	1		
110	06331-35010	PLUG	BOUCHON	STOPFEN	1		
120	04724-00100	GASKET	JOINT	DICHTUNGSPLATTE	1		
130	14971-5641-0	SPRING, GOVERNOR	RESSORT DE REGULATEUR	REGLERFEDER	1		
140	14911-5648-0	SPRING, IDLING	RESSORT, RALENTI	FEDER	1		
150	07715-03205	BALL	BILLE	KUGEL	1		

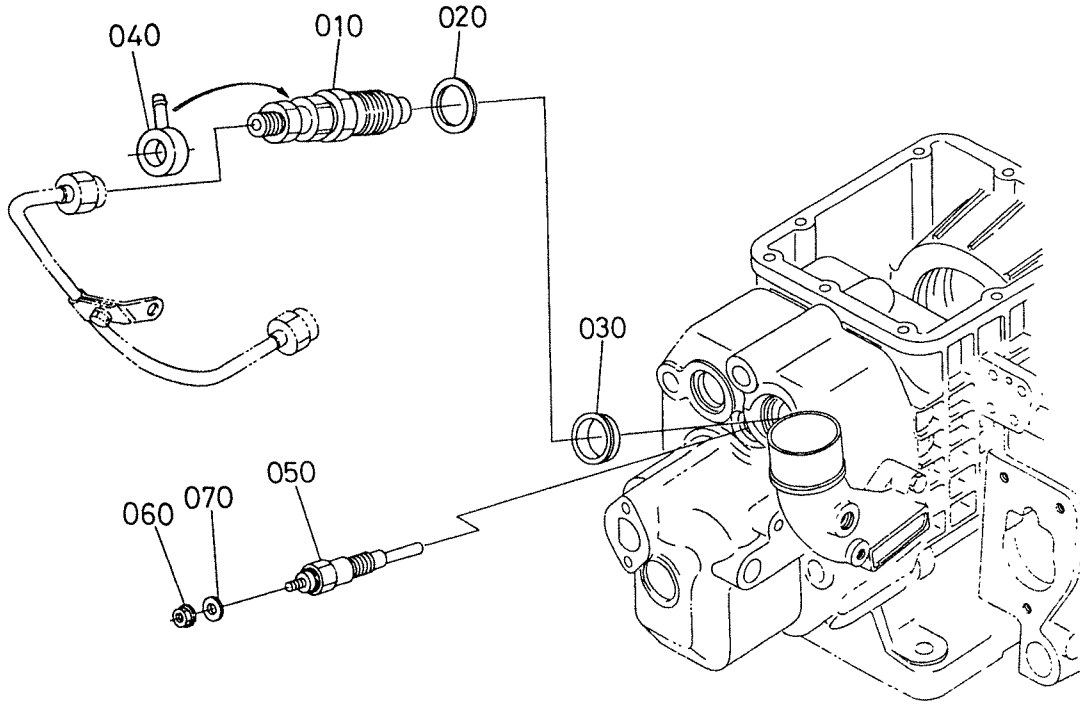

19701-018-20

A:EA300-ENB1-1

REF.No POS.No BILD-Nr	PART No. REFERENCE BESTELL-Nr.	PART NAME	DESIGNATION	BEZEICHNUNG	Q' TY/S. No.	I.C.	REMARKS REMARQUES BEMERKUNGEN
					Q' TE/No. S. STUECK/S. Nr.		
010	1G111-5300-0	ASSY HOLDER, NOZZLE	ENS. PORTE-INJECTEUR	GRP. DUESENHALTER	A		
020	15841-5362-2	GASKET	JOINT	DICHTUNGSPLATTE	1		
030	19077-5365-0	SEAL, HEAT	JOINT DE CHALEUR	DICHTUNG	1		
040	1G111-9568-0	JOINT, NOZZLE HOLDER	RACCORD DE PORTE-IN.	ANSCHLUSS	1		
050	16851-6551-0	GLOW PLUG	BOUGIE, PRE-CHAUFFAGE	GLEUHSTOEPSSEL	1		
060	02761-50040	NUT, FLANGE	ECROU A EMBASE	FLANSCHEN-MUTTER	1		
070	04013-60040	WASHER, PLAIN	RONDELLE FREIN	SCHEIBE	1		

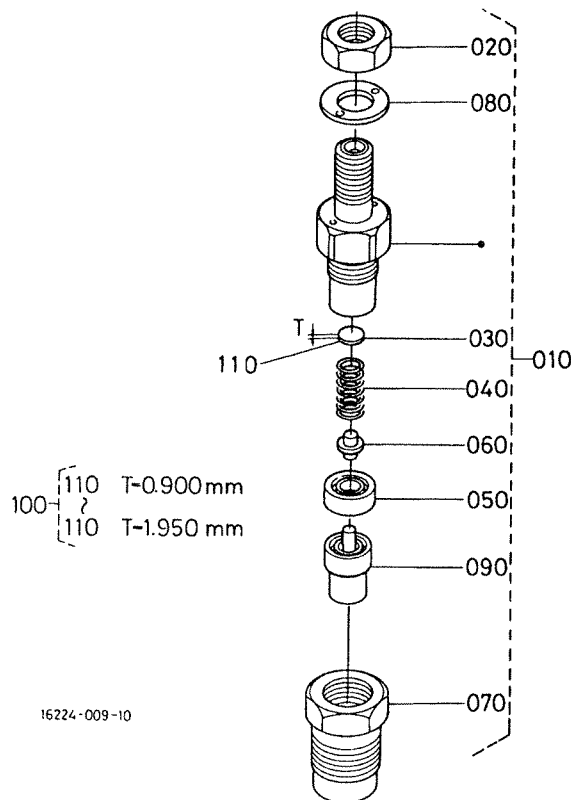

A:EA300-ENB1-1

REF.No POS.No BILD-Nr	PART No. REFERENCE BESTELL-Nr.	PART NAME	DESIGNATION	BEZEICHNUNG	Q' TY/S. No. Q' TE/No. S. STUECK/S. Nr.	I. C.	REMARKS REMARQUES BEMERKUNGEN
					A		
010	1G111-5300-0	ASSY HOLDER, NOZZLE	ENS. PORTE-INJECTEUR	GRP. DUESENHALTER	1		
020	15841-9203-0	NUT	ECROU	MUTTER	1		
030	15841-5323-0	WASHER, ADJUSTING	RONDELLE DE REGLAGE	EINSTELLSCHEIBE	1		
040	15841-5317-0	SPRING, NOZZLE	RESSORT D' INJECTEUR	FEDER	1		
050	15841-5335-0	PIECE, DISTANCE	CALE DE BLOCAGE	DISTANZSCHEIBE	1		
060	15841-5316-0	PUSH ROD	TIGE DE POUSSOIR	STOSSELSTANGE	1		
070	16475-5328-0	NUT, NOZZLE	ECROU D' INJECTEUR	MUTTER	1		
080	15841-9404-0	WASHER	RONDELLE	SCHEIBE	1		
090	15841-5361-0	PIECE, NOZZLE	ELEMENT D' INJECTEUR	DUESENSTUECK	1		
100	15841-9810-0	ASSY WASHER, ADJUST	ENS. RONDELLE	GRP. EINSTELLSCHEIBE	1		OPTION
110	15841-5323-0	WASHER, ADJUSTING	RONDELLE DE REGLAGE	EINSTELLSCHEIBE	1		0.900mm
110	15841-9851-0	WASHER, ADJUSTING	RONDELLE DE REGLAGE	EINSTELLSCHEIBE	1		0.925mm
110	15841-9852-0	WASHER, ADJUSTING	RONDELLE DE REGLAGE	EINSTELLSCHEIBE	1		0.950mm
110	15841-9853-0	WASHER, ADJUSTING	RONDELLE DE REGLAGE	EINSTELLSCHEIBE	1		0.975mm
110	15841-9854-0	WASHER, ADJUSTING	RONDELLE DE REGLAGE	EINSTELLSCHEIBE	1		1.100mm
110	15841-9855-0	WASHER, ADJUSTING	RONDELLE DE REGLAGE	EINSTELLSCHEIBE	1		1.025mm
110	15841-9856-0	WASHER, ADJUSTING	RONDELLE DE REGLAGE	EINSTELLSCHEIBE	1		1.050mm
110	15841-9857-0	WASHER, ADJUSTING	RONDELLE DE REGLAGE	EINSTELLSCHEIBE	1		1.075mm
110	15841-9858-0	WASHER, ADJUSTING	RONDELLE DE REGLAGE	EINSTELLSCHEIBE	1		1.100mm
110	15841-9859-0	WASHER, ADJUSTING	RONDELLE DE REGLAGE	EINSTELLSCHEIBE	1		1.125mm
110	15841-9860-0	WASHER, ADJUSTING	RONDELLE DE REGLAGE	EINSTELLSCHEIBE	1		1.150mm
110	15841-9861-0	WASHER, ADJUSTING	RONDELLE DE REGLAGE	EINSTELLSCHEIBE	1		1.175mm
110	15841-9862-0	WASHER, ADJUSTING	RONDELLE DE REGLAGE	EINSTELLSCHEIBE	1		1.200mm
110	15841-9863-0	WASHER, ADJUSTING	RONDELLE DE REGLAGE	EINSTELLSCHEIBE	1		0.900mm
110	15841-9864-0	WASHER, ADJUSTING	RONDELLE DE REGLAGE	EINSTELLSCHEIBE	1		1.250mm
110	15841-9865-0	WASHER, ADJUSTING	RONDELLE DE REGLAGE	EINSTELLSCHEIBE	1		1.275mm
110	15841-9866-0	WASHER, ADJUSTING	RONDELLE DE REGLAGE	EINSTELLSCHEIBE	1		1.300mm
110	15841-9867-0	WASHER, ADJUSTING	RONDELLE DE REGLAGE	EINSTELLSCHEIBE	1		1.325mm
110	15841-9868-0	WASHER, ADJUSTING	RONDELLE DE REGLAGE	EINSTELLSCHEIBE	1		1.350mm
110	15841-9869-0	WASHER, ADJUSTING	RONDELLE DE REGLAGE	EINSTELLSCHEIBE	1		1.375mm

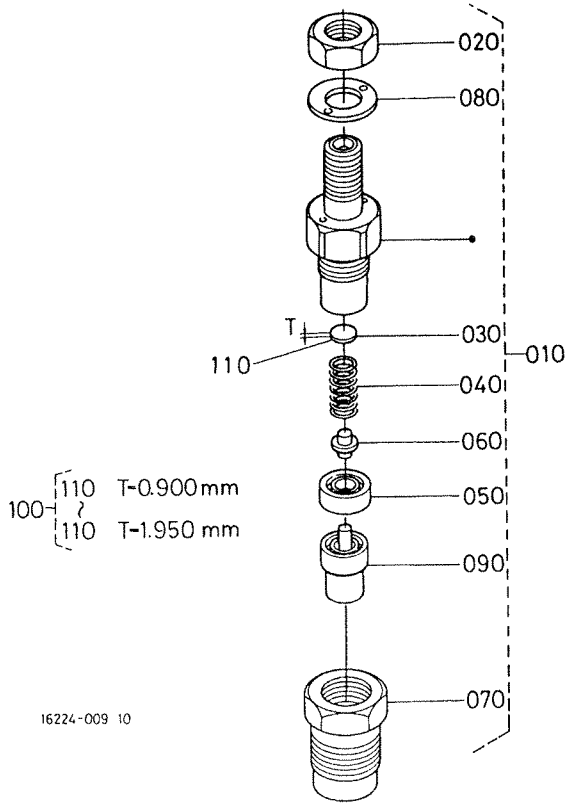

16224-009 10

A:EA300-ENB1-1

REF.No. POS.No. BILD-Nr.	PART No. REFERENCE BESTELL-Nr.	PART NAME	DESIGNATION	BEZEICHNUNG	Q'TY/S. No. Q'TE/No. S. STUECK/S. Nr.	I.C.	REMARKS REMARQUES BEMERKUNGEN
110	15841-9870-0	WASHER, ADJUSTING	RONDELLE DE REGLAGE	EINSTELLSCHEIBE	A		1. 400mm
110	15841-9871-0	WASHER, ADJUSTING	RONDELLE DE REGLAGE	EINSTELLSCHEIBE	1		1. 425mm
110	15841-9872-0	WASHER, ADJUSTING	RONDELLE DE REGLAGE	EINSTELLSCHEIBE	1		1. 450mm
110	15841-9873-0	WASHER, ADJUSTING	RONDELLE DE REGLAGE	EINSTELLSCHEIBE	1		1. 475mm
110	15841-9874-0	WASHER, ADJUSTING	RONDELLE DE REGLAGE	EINSTELLSCHEIBE	1		1. 500mm
110	15841-9875-0	WASHER, ADJUSTING	RONDELLE DE REGLAGE	EINSTELLSCHEIBE	1		1. 525mm
110	15841-9876-0	WASHER, ADJUSTING	RONDELLE DE REGLAGE	EINSTELLSCHEIBE	1		1. 550mm
110	15841-9877-0	WASHER, ADJUSTING	RONDELLE DE REGLAGE	EINSTELLSCHEIBE	1		1. 575mm
110	15841-9878-0	WASHER, ADJUSTING	RONDELLE DE REGLAGE	EINSTELLSCHEIBE	1		1. 600mm
110	15841-9879-0	WASHER, ADJUSTING	RONDELLE DE REGLAGE	EINSTELLSCHEIBE	1		1. 625mm
110	15841-9880-0	WASHER, ADJUSTING	RONDELLE DE REGLAGE	EINSTELLSCHEIBE	1		1. 650mm
110	15841-9881-0	WASHER, ADJUSTING	RONDELLE DE REGLAGE	EINSTELLSCHEIBE	1		1. 675mm
110	15841-9882-0	WASHER, ADJUSTING	RONDELLE DE REGLAGE	EINSTELLSCHEIBE	1		1. 700mm
110	15841-9883-0	WASHER, ADJUSTING	RONDELLE DE REGLAGE	EINSTELLSCHEIBE	1		1. 725mm
110	15841-9884-0	WASHER, ADJUSTING	RONDELLE DE REGLAGE	EINSTELLSCHEIBE	1		1. 750mm
110	15841-9885-0	WASHER, ADJUSTING	RONDELLE DE REGLAGE	EINSTELLSCHEIBE	1		1. 775mm
110	15841-9886-0	WASHER, ADJUSTING	RONDELLE DE REGLAGE	EINSTELLSCHEIBE	1		1. 800mm
110	15841-9887-0	WASHER, ADJUSTING	RONDELLE DE REGLAGE	EINSTELLSCHEIBE	1		1. 825mm
110	15841-9888-0	WASHER, ADJUSTING	RONDELLE DE REGLAGE	EINSTELLSCHEIBE	1		1. 850mm
110	15841-9889-0	WASHER, ADJUSTING	RONDELLE DE REGLAGE	EINSTELLSCHEIBE	1		1. 875mm
110	15841-9890-0	WASHER, ADJUSTING	RONDELLE DE REGLAGE	EINSTELLSCHEIBE	1		1. 900mm
110	15841-9891-0	WASHER, ADJUSTING	RONDELLE DE REGLAGE	EINSTELLSCHEIBE	1		1. 925mm
110	15841-9892-0	WASHER, ADJUSTING	RONDELLE DE REGLAGE	EINSTELLSCHEIBE	1		1. 950mm

0300

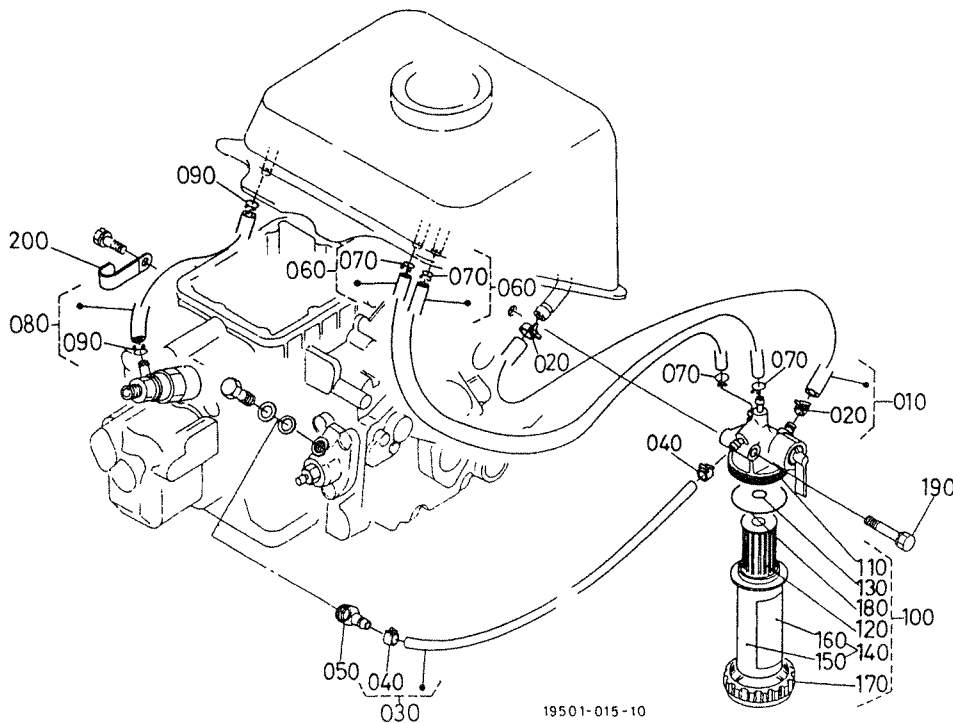
**FUEL FILTER
 FILTRE A CARBURANT
 KRAFTSTOFFFILTER**
B11-R

A:EA300-ENB1-1

REF.No POS.No BILD-Nr	PART No. REFERENCE BESTELL-Nr.	PART NAME	DESIGNATION	BEZEICHNUNG	Q' TY/S. No. Q' TE/No. S. STUECK/S. Nr.	I.C.	REMARKS REMARQUES BEMERKUNGEN
010	14279-4201-0	ASSY PIPE, FUEL	ENS. TUYAU CARBURANT	GRP. KRAFTSTOFFROHR	1		
020	14911-4275-0	CLIP, PIPE	ATTACHE	ROHRKLEMME	2		
030	14971-4202-0	ASSY PIPE, FUEL	ENS. TUYAU CARBURANT	GRP. KRAFTSTOFFROHR	1		
040	14911-4275-0	CLIP, PIPE	ATTACHE	ROHRKLEMME	2		
050	14111-4241-0	JOINT, EYE	RACCORD	VERBINDUNGSSTUECK	1		
060	14279-4220-0	ASSY PIPE, AIR VENT	ENS. TUYAU	TUBE	2		
070	14971-4275-0	CLIP, PIPE	ATTACHE	ROHRKLEMME	4		
080	14279-4250-0	ASSY PIPE, OVER FLOW	ENS. TUYAU TROP-PLEIN	GRP. UEBERLAUFROHR	1		
090	14971-4275-0	CLIP, PIPE	ATTACHE	ROHRKLEMME	2		
100	14911-4301-4	ASSY FILTER, FUEL	ENS. FILTRE, COMBUST	GRP. KRAFTSTOFFFILTER	1		
110	14911-4351-3	COMP. BODY, FILTER	CORPS, COMP	KAROSSERIE	1		
120	15231-4356-0	ASSY ELEMENT	ENS. ELEMENT	FILTREINSATZ	1		
130	14301-4357-0	O RING, FILTER	JOINT TORIQUE FILT.	O RING	1		
140	15393-4310-0	ASSY CUP, FILTER	ENS. CHAPEAU DE FILTR	GRP. FILTERTOPF	1		
150	15393-4358-0	CUP, FILTER	CHAPEAU DE FILTRE	FILTERTOPF	1		
160	16873-8843-0	LABEL, FUEL FILTER	ETIQUETTE	AUFKLEBER, KRAFTSTF.	1		
170	14301-4359-0	RING, RETAINING	BAGUE DE RETENUE	HALTERING	1		
180	14301-4365-0	O RING, FILTER CUP	JOINT	O RING	1		
190	01123-50845	BOLT	VIS	BOLZEN	1		
200	15272-6757-0	CLAMP, CORD	ATTACHE-FILS	KABELKLEMME	3		

0304

FUEL TANK
RESERVOIR A CARBURANT
KRAFTSTOFFBEHAELTER

B12-L

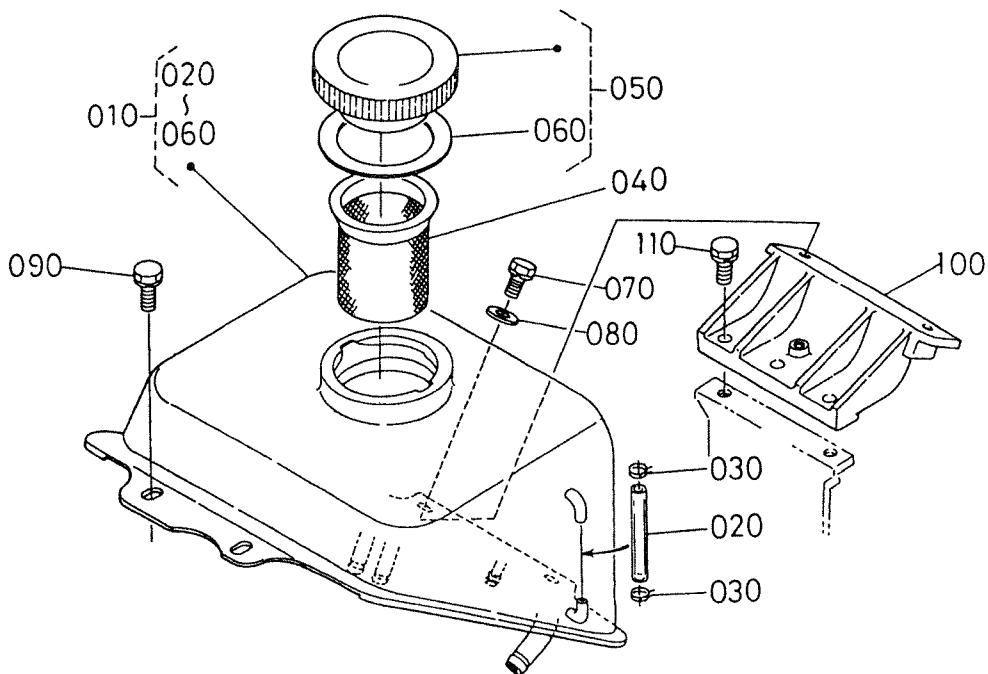

19501-012-10

A:EA300-ENB1-1

REF.No POS.No BILD-Nr	PART No. REFERENCE BESTELL-Nr.	PART NAME	DESIGNATION	BEZEICHNUNG	Q' TY/S. No. Q' TE/No. S. STUECK/S. Nr.	I.C.	REMARKS REMARQUES BEMERKUNGEN
					A		
010	14279-4101-8	ASSY TANK, FUEL	RESERVOIR A CARBURAN	KRAFTSTOFFBEHAELTER	1		
020	14279-4171-0	GAUGE, FUEL	JAUGE A CARB	TREIBSTOFFANZEIGE	1		
030	14301-4236-0	CLIP	ATTACHE	SHELLE	2		
040	12545-4135-0	FILTER, FUEL TANK	FILTRE A ESSENCE	KRAFTSTOFFSIED	1		
050	12521-4103-0	ASSY CAP, FUEL TANK	BOUCHON DE RESERVOIR	GRP. TANKVERSCHLUSS	1		
060	12521-4134-0	GASKET, TANK CAP	JOINT	DICHTUNG, TANKVERSCH.	1		
070	01123-50820	BOLT	VIS	BOLZEN	3		
080	04013-60080	WASHER, PLAIN	RONDELLE FREIN	SCHEIBE	3		
090	01123-50845	BOLT	VIS	BOLZEN	1		
100	14279-4113-2	SUPPORT, FUEL TANK	SUP. RESERV. A CARBUR	TRAEGER	1		
110	01023-50622	BOLT	VIS	BOLZEN	2		

0404

STARTER
DEMARREUR
ANLASSER

B12-R

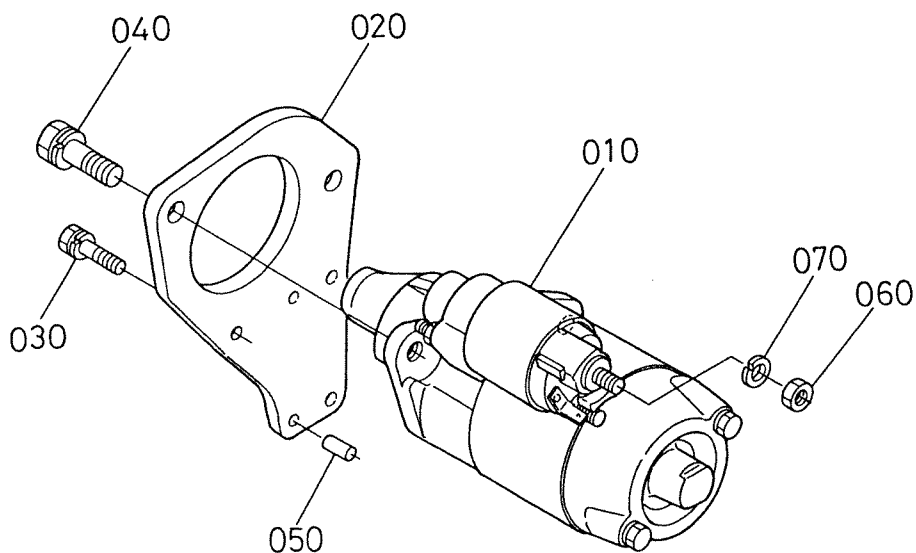

19701-029-10

A:EA300-ENB1-1

REF.No. POS.No. BILD-Nr.	PART No. REFERENCE BESTELL-Nr.	PART NAME	DESIGNATION	BEZEICHNUNG	Q' TY/S. No.	I.C.	REMARKS REMARQUES BEMERKUNGEN
					Q' TE/No. S. STUECK/S. Nr.		
010	14278-6301-0	ASSY STARTER	ENS. DEMARREUR	GRP. ANLASSER	A		
020	14278-6389-3	SUPPORT, STARTER	SUPPORT DE DEMARREUR	TRAEGERANLASSER	1		
030	01023-50618	BOLT	VIS	BOLZEN	3		
040	01133-51030	BOLT	VIS	BOLZEN	2		
050	05012-00614	PIN, STRAIGHT	GOUPILLE CYLINDRIQUE	ZYLINDERSTIFT	2		
060	02156-50080	NUT	ECROU	MUTTER	1		
070	04512-60080	WASHER, SPRING	RONDELLE GROWER	FEDERRING	1		

0405

STARTER (COMPONENT PARTS)
 DEMARREUR (PARTIES COMPOSANTES)
 ANLASSER (EINZEL-TEIL)

B13-L

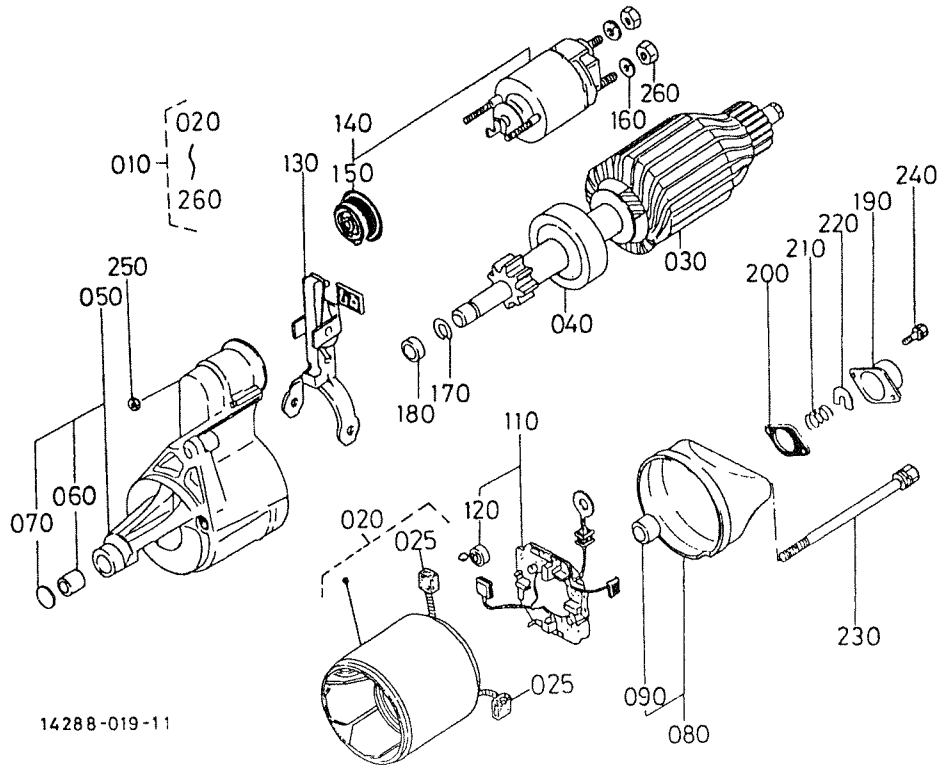

A:EA300-ENB1-1

REF.No. POS.No. BILD-Nr.	PART No. REFERENCE BESTELL-Nr.	PART NAME	DESIGNATION	BEZEICHNUNG	Q' TY/S. No. Q' TE/No. S. STUECK/S. Nr.	I.C.	REMARKS REMARQUES BEMERKUNGEN
					A		
010	14278-6301-0	ASSY STARTER	ENS. DEMARREUR	GRP. ANLASSER	1		
020	14278-6308-0	ASSY YOKE, STARTER	ENS. FOURCHE	GRP. GABELGELENK	1		
025	14278-6311-0	KIT STARTER	BORNE ET PLONGEUR	ANLASSER, ZUSAMMENBAU	2		
030	14278-6307-0	ARMATURE	ARMATURE	ARMATUR	1		
040	14278-6304-0	CLUTCH, OVER RUNNING	EMBRAYAGE A INERTIE	AUFLAUFKUPPLUNG	1		
050	14278-6303-0	ASSY FRAME	ENS. CHASSIS	KOMP. RAHMEN	1		
060	17016-6325-0	BUSH	BAGUE	BUCHSE	1		
070	14278-9616-0	PLUG, EXPANSION	BOUCHON EXPANSIBLE	STOEPSSEL, AUSDEHNUNG	1		
080	14278-6320-0	ASSY FRAME, END	ENS. EXTREM, DE CHASSI	ENDRAHMEN	1		
090	14278-6325-0	BUSH	BAGUE	BUCHSE	1		
100	----	BLANK	BLANC	LEERE SPALTE	-		
110	14278-6338-0	ASSY HOLDER, BRUSH	ENS. SUPPORT	GRP. BUERSTENHALTER	1		
120	14278-6339-0	SPRING, BRUSH	RESSORT DE BALAI	SCHLEIFBUERSTENFEDER	4		
130	14278-6305-0	LEVER, DRIVE	LEVIER D'ENTRAINE.M.	ANTRIEBHABEL	1		
140	15231-6302-2	SWITCH, MAGNETIC	INTERRUP. MAGNETIQUE	MAGNETSCHALTER	1		
150	14278-6345-0	COVER	COUVERCLE	DECKEL	1		
160	14278-9401-0	WASHER, PLAIN	RONDELLE FREIN	SCHEIBE	1		
170	15221-9482-0	PIN, SNAP	GOUPILLE BETA	SICHERUNGSTIFT	1		
180	15321-6325-0	NUT, PINION STOP	ECROU D'ARRET DE PIQ	MUTTER	1		
190	14278-6351-0	CAP, END FRAME	BOUCHON DE LANCEUR	ABSCHLUSSRAHMENKAPPE	1		
200	14278-6352-0	GASKET	JOINT	DICHTUNGSPLATTE	1		
210	14278-6319-0	SPRING, BRAKE	RESSORT DE FREIN	BREMSFEDER	1		
220	14278-6318-0	SHOE, BRAKE	SABOT DE FREIN	BREMSBACKE	1		
230	14278-6332-0	BOLT, THROUGH	VIS, PASSANT	DURCHGEHENDERBOLZEN	2		
240	03024-50414	SCREW, WITH WASHER	VIS	SCHRAUBE	2		
250	14278-9201-0	NUT	ECROU	MUTTER	2		
260	02112-50080	NUT	ECROU	MUTTER	1		

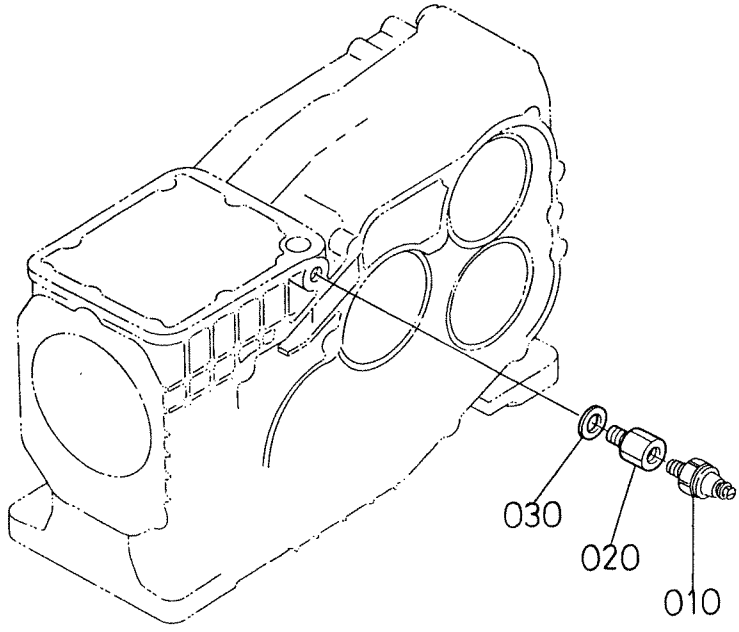

19701-019-20

A:EA300-ENB1-1

REF.No POS.No BILD-Nr	PART No. REFERENCE BESTELL-Nr.	PART NAME	DESIGNATION	BEZEICHNUNG	Q' TY/S. No. Q' TE/No. S. STUECK/S. Nr.	I.C.	REMARKS REMARQUES BEMERKUNGEN
					A		
010	14611-3609-0	SIGNAL, OIL	PETROLE LAMPANT	LEUCHTPETROLEUM	1		
020	14971-3611-2	HOLDER, OIL-SIGNAL	SUPPORT, SIGNAL HUILE	HALTER	1		
030	04724-00100	GASKET	JOINT	DICHTUNGSPLATTE	1		

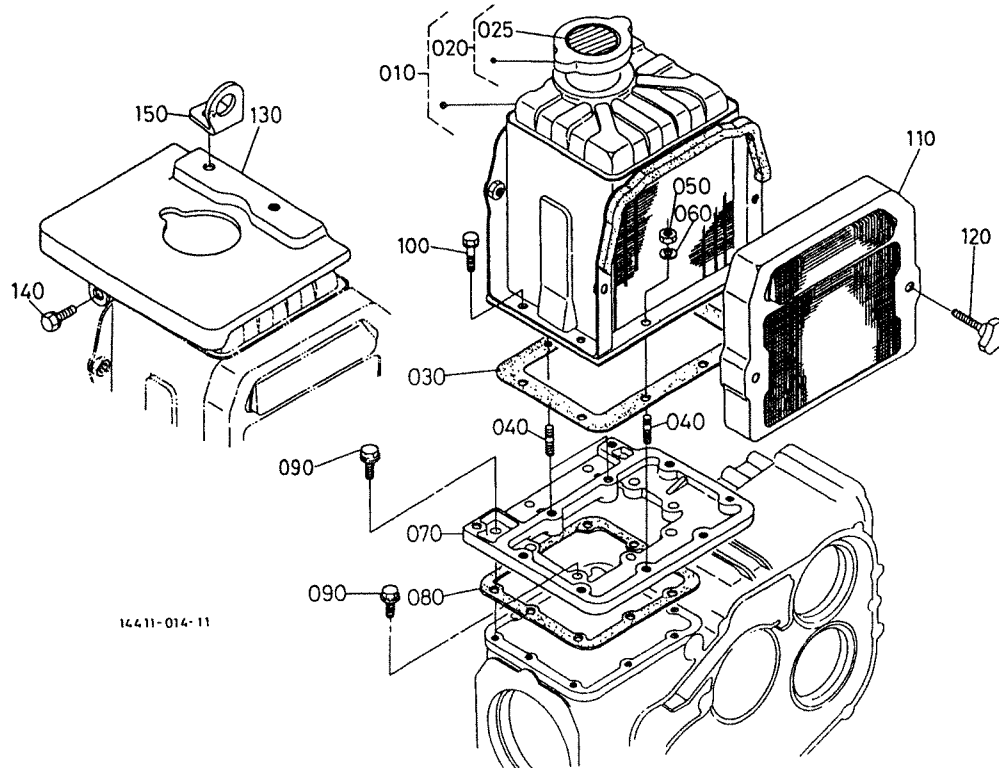

A:EA300-ENB1-1

REF.No. POS.No. BILD-Nr	PART No. REFERENCE BESTELL-Nr.	PART NAME	DESIGNATION	BEZEICHNUNG	Q' TY/S. No.		REMARKS REMARQUES BEMERKUNGEN
					Q' TE/No. S. STUECK/S. Nr.	I. C.	
010	14274-7206-0	ASSY RADIATOR	ENS. RADIATEUR	GRP. KUEHLER	1		
020	11131-7203-0	ASSY CAP, RADIATOR	BOUCHON COMPLET	KUEHLERVERSCHLUSS	1		
025	11131-8724-0	LABEL, CAUTION	ETIQUETTE	AUFKLEBER, ACHTUNG	1		
030	14971-7212-0	GASKET, RADIATOR	JOINT, RADIATEUR	DICHTUNGSPLATTE	1		
040	01518-50616	STUD	GOUJON	STEBBOLZEN	3		
050	02014-50060	NUT	ECROU	MUTTER	3		
060	04512-60060	WASHER, SPRING	RONDELLE GROWER	FEDERRING	3		
070	14971-7214-0	BASE, RADIATOR	BASE DU RADIATEUR	UNTERBAU KUEHLER	1		
080	14595-7245-0	GASKET, RADIATOR	JOINT, RADIATEUR	DICHTUNGSPLATTE	1		
090	01754-50618	BOLT, FLANGE	VIS DE BUTEE	FLANSCHEN-BOLZEN	9		
100	01023-50620	BOLT	VIS	BOLZEN	5		
110	14971-7225-0	NET, RADIATOR	GRILLE DE RADIATEUR	KUEHLERNETZ	1		
120	01820-50635	BOLT, KNOB	VIS	BOLZEN	2		
130	14279-7221-0	COVER, RADIATOR	COUVERCLE	KUEHLERSCHUTZ	1		
140	01023-50616	BOLT	VIS	BOLZEN	1		
150	14279-0174-0	HOOK, ENGINE	ANNEAU DE LEVAGE	MOTOR-ANKERHAKEN	1		

0504

FAN
VENTILATEUR
VENTILATOR

B14-R

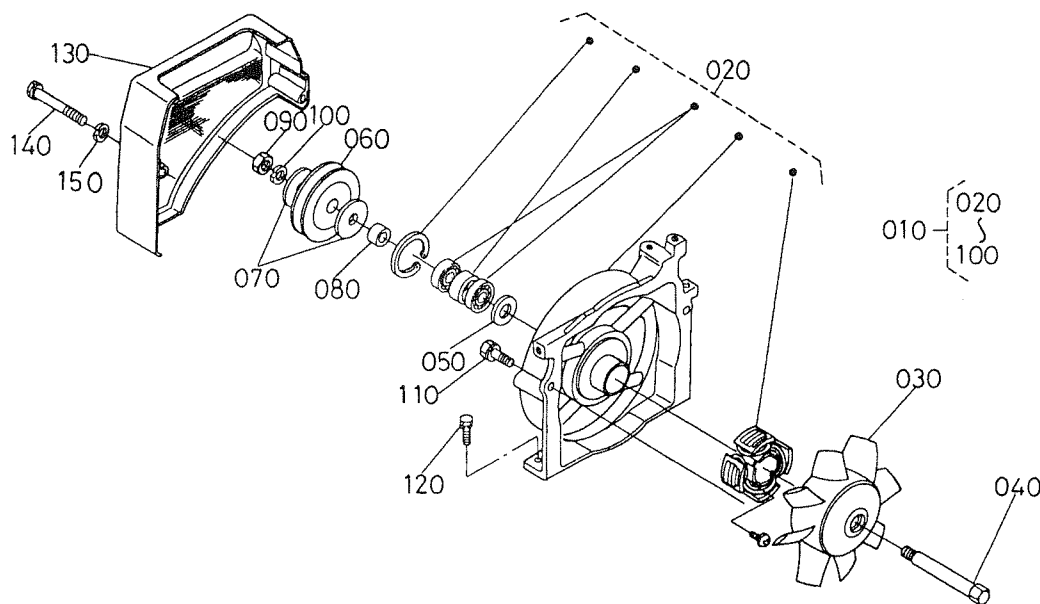

19501-018-20

A:EA300-ENB1-1

REF.No POS.No BILD-Nr	PART No. REFERENCE BESTELL-Nr.	PART NAME	DESIGNATION	BEZEICHNUNG	Q'TY/S. No. Q'TE/No. S. STUECK/S. Nr.	I.C.	REMARKS REMARQUES BEMERKUNGEN
010	14279-7401-0	ASSY FAN, COOLING	ENS. VENTILATEUR, R/R	LUFTER, KUHLUNG	1		
020	14279-7410-0	COMP. BRACKET, FAN	PLAQUE-SUPPORT, VENTI	HALTER, LUFTER	1		
030	14279-7411-0	FAN	VENTILATEUR	VENTILATOR	1		
040	14972-7414-0	SHAFT, FAN	ARBRE DE VENTIL.	SCHAFT	1		
050	14972-7417-0	WASHER, FAN	RONDELLE VENTIL	EINLAGESTUECK	1		
060	14972-7425-0	PULLEY, FAN	POULIE VENTILATEUR	VENTILATORSCHIEBE	1		
070	14972-7424-0	WASHER, FAN	RONDELLE VENTIL	EINLAGESTUECK	2		
080	14972-7415-0	COLLAR, FAN	COLLIER	VENTILATORHUELSE	1		
090	02112-50120	NUT	ECROU	MUTTER	1		
100	04512-60120	WASHER, SPRING	RONDELLE GROWER	FEDERRING	1		
110	01023-50616	BOLT	VIS	BOLZEN	2		
120	01023-50620	BOLT	VIS	BOLZEN	2		
130	14971-7412-0	COVER, FAN	COUVERCLE, VENT/L	VENTILATORDECKEL	1		
140	01053-50660	BOLT	VIS	BOLZEN	2		
150	04512-60060	WASHER, SPRING	RONDELLE GROWER	FEDERRING	2		

0506

TENSION PULLEY
POULIE DE TENSION
SPANENNROLLE

B15-L

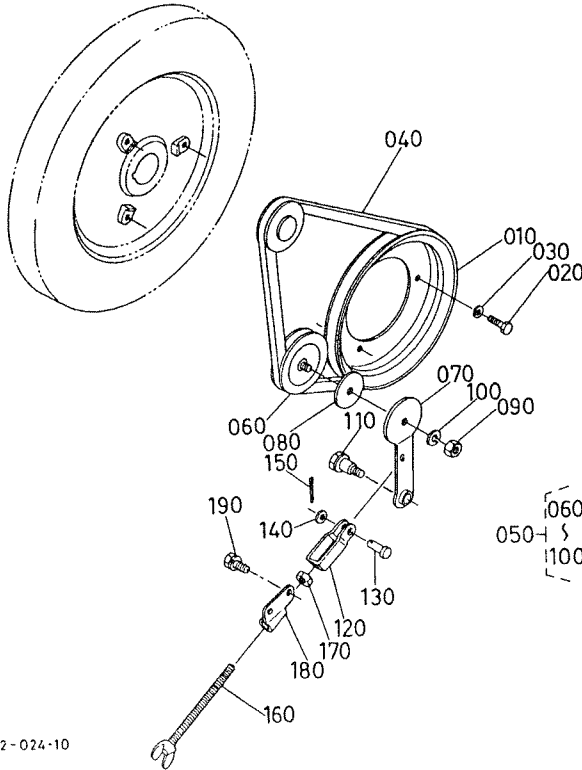

11992-024-10

A:EA300-ENB1-1

REF.No POS.No BILD-Nr	PART No. REFERENCE BESTELL-Nr.	PART NAME	DESIGNATION	BEZEICHNUNG	Q' TY/S. No. Q' TE/No. S. STUECK/S. Nr.	I. C.	REMARKS REMARQUES BEMERKUNGEN
010	14971-7428-0	PULLEY, FAN DRIVE	POULIE ENTRAIN. VENT.	RIEMNSCHEIBE	1		
020	01053-50614	BOLT	VIS	BOLZEN	3		
030	04512-60060	WASHER, SPRING	RONDELLE GROWER	FEDERRING	3		
040	14971-9701-0	V BELT	COURROIE	RIEMEN	1		
050	14971-7430-2	ASSY PULLEY, TENSION	ENS. POULIE, TENSION	GRP. SPANNROLLE	1		
060	14541-7432-2	PULLEY, TENSION	POULIE DE TENSION	SPANNROLLE	1		
070	14971-7441-0	SUPPORT, TEN. PULLEY	SUPPORT DE POULIE	TRAEGER	1		
080	14911-7477-0	CAP	BOUCHON	KAPPE	1		
090	02052-50080	NUT	ECROU	MUTTER	1		
100	04512-60080	WASHER, SPRING	RONDELLE GROWER	FEDERRING	1		
110	14971-9131-0	BOLT, REAMER	VIS DE CENTRAGE	BOLZEN	1		
120	14971-7436-2	ASSY PULLEY, TENSION	ENS. POULIE, TENSION	GRP. SPANNROLLER	1		
130	05122-50816	PIN, JOINT	GOUPILLE	STIFT	1		
140	04012-50080	WASHER, PLAIN	RONDELLE FREIN	SCHEIBE	1		
150	05511-50215	PIN, SPLIT	GOUPILLE FENDUE	SPLINTSTIFT	1		
160	19701-7494-0	BOLT, TENSION	VIS DE TENSION	SPANNBOLZEN	1		
170	02014-50060	NUT	ECROU	MUTTER	1		
180	14971-7495-2	GUIDE, TENSION BOLT	GUIDE	FUHRUNGSOSE	1		
190	01023-50612	BOLT	VIS	BOLZEN	2		

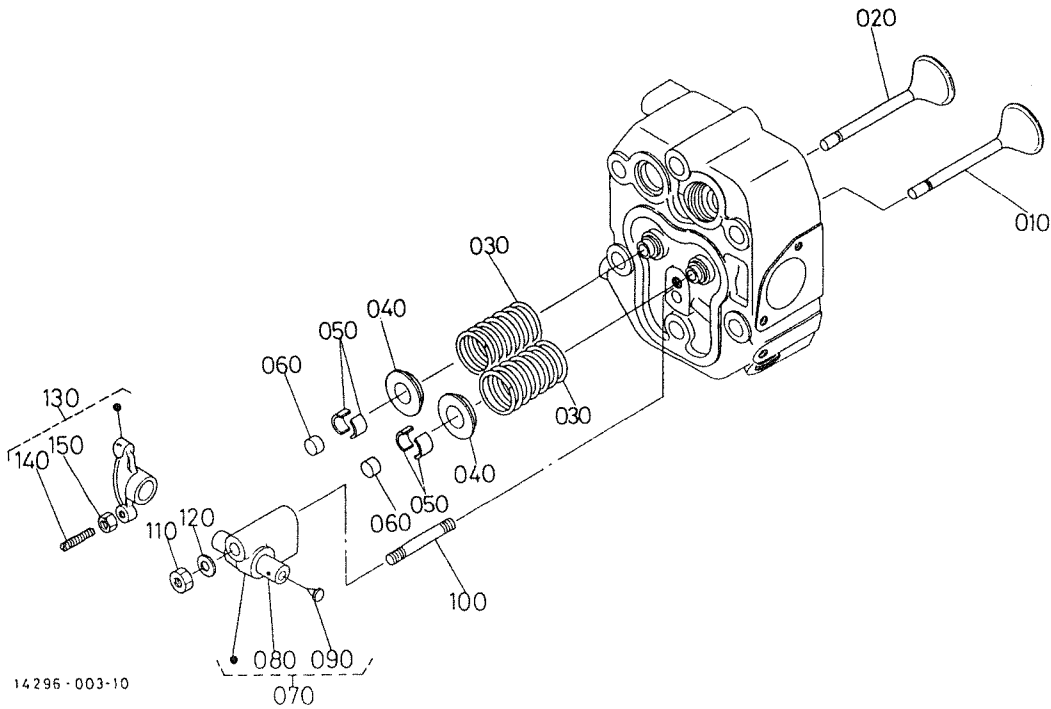

14 296 - 003-10

A:EA300-ENB1-1

REF.No. POS.No. BILD-Nr	PART No. REFERENCE BESTELL-Nr.	PART NAME	DESIGNATION	BEZEICHNUNG	Q' TY/S. No. Q' TE/No. S. STUECK/S. Nr.	I. C.	REMARKS REMARQUES BEMERKUNGEN
					A		
010	14972-1311-0	VALVE, INLET	SOUPAPE D' ADMISSION	EINLASSVENTIL	1		
020	14972-1312-0	VALVE, EXHAUST	SOUPAPE D' ECHAPMENT	AUSLASSVENTIL	1		
030	15261-1324-0	SPRING, VALVE	RESSORT DE SOUPE	VENTIL-FEDER	2		
040	16241-1333-0	RETAINER, VALVE SP.	CUVETTE SUPERIEURE	ZURUECKHALTER	2		
050	15261-1336-0	COLLET, VALVE SPRING	DEMI CLAVETTE	KLEMMSCHEIBE	2	SET	
060	16241-1328-0	CAP, VALVE	CHAPEAU DE SOUPE	VENTILKAPPE	2		
070	14971-1405-0	COMP BRACKET, R. ARM	PLAQUE-SUPPORT COMP	HALTER	1		
080	14971-1406-0	COMP. SHAFT, ROCKERARM	ARBRE COMP. CULBUT.	WELLE	1		
090	03410-50606	SCREW, SET	VIS D' ARRET	ANSCHLAGSCHRAUBE	1		
100	15261-1441-0	STUD	GOUJON	STEBOLZEN	1		
110	15261-9201-0	NUT	ECROU	MUTTER	1		
120	15261-9401-0	WASHER, PLAIN	RONDELLE FREIN	SCHEIBE	1		
130	15271-1403-0	ASSY ROCKER ARM	ENS. CULBUTEURS	GRP. KIPPHEBEL	2		
140	15261-1423-2	SCREW, ADJUSTING	VIS DE REGLAGE	STELLSCHRAUBE	2		
150	15261-1424-0	NUT	ECROU	MUTTER	2		

0603

AIR CLEANER
 FILTRE A AIR
 LUFTREINHEIT

B16-L

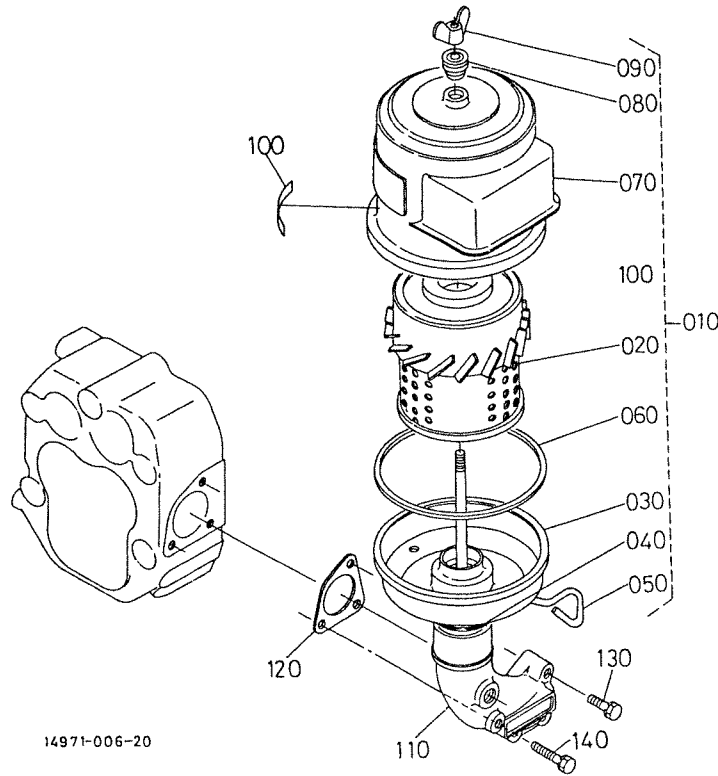

A:EA300-ENB1-1

REF.No. POS.No. BILD-Nr	PART No. REFERENCE BESTELL-Nr.	PART NAME	DESIGNATION	BEZEICHNUNG	Q'TY/S. No. Q' TE/No. S. STUECK/S. Nr.	I.C.	REMARKS REMARQUES BEMERKUNGEN
					A		
010	14971-1101-2	ASSY CLEANER, AIR	ENS. FILTRE A AIR	GRP. LUFTFILTER	1		
020	14971-1118-0	ELEMENT, AIR CLEANER	ELEMENT FILTRE A AIR	LUFTFILTERELEMENT	1		
030	14971-1105-0	COMP. BODY	CORPS COMP.	KOERPER KOMP.	1		
040	14971-1152-0	O RING	JOINT TORIQUE	O RING	1		
050	14911-1146-0	BOLT, FITTING	BOULON	BOLZEN	1		
060	14971-1117-0	GASKET	JOINT	DICHTUNGSPLATTE	1		
070	14971-1110-0	COMP. CASE	CARTER COMP.	GEHAUSE	1		
080	14911-1192-0	GROMMET	GRUMMET	GUMMITUELLE	1		
090	14911-1153-0	NUT, WING	ECROU A AILETTES	MUTTER	1		
100	14971-8845-0	LABEL	ETIQUETTE	AUFKLEBER	1		
110	14971-1161-4	FLANGE, AIR CLEANER	FLASQUE FILTRE A AIR	FLANSCH, LUFTFILTER	1		
120	14971-1165-0	PACKING, FLANGE	JOINT	DICHTUNGSMATERIAL	1		
130	01023-50622	BOLT	VIS	BOLZEN	1		
140	01023-50632	BOLT	VIS	BOLZEN	2		

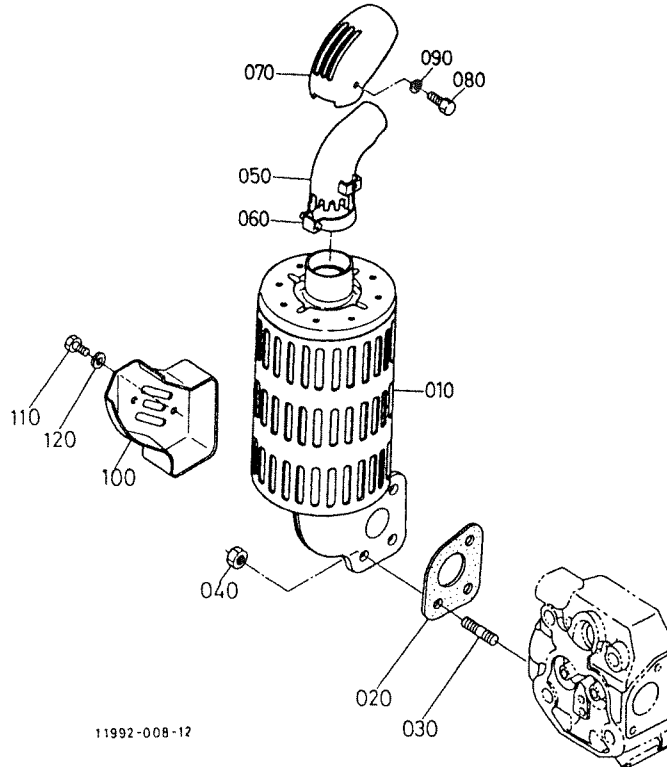

A:EA300-ENB1-1

REF.No. POS.No. BILD-Nr	PART No. REFERENCE BESTELL-Nr.	PART NAME	DESIGNATION	BEZEICHNUNG	Q' TY/S. No. Q' TE/No. S. STUECK/S. Nr.	I.C.	REMARKS REMARQUES BEMERKUNGEN
010	14971-1211-2	MUFFLER, KS BLACK	SILENCIEUX	AUSPUFFTOPF	A		
020	14595-1223-0	GASKET, MUFFLER	JOINT DE SILENCIEUX	DICHTUNG, AUSPUFFTOPF	1		
030	01513-50816	STUD	GOUJON	STEBBOLZEN	3		
040	02114-50080	NUT	ECROU	MUTTER	3		
050	14911-1241-2	PIPE, MUFFLER	TUYAU DE SILENCIEUX	AUSPUFFTOPFRHR	1		
060	14431-1243-0	BAND, PIPE	COLLIER DE TUYAU	ROHRBAND	1		
070	14911-1247-0	COVER, MUFFLER PIPE	PROTECTION DE TUYAU	ABDECKUNG, AUSPUFF.	1		
080	01053-50608	BOLT	VIS	BOLZEN	2		
090	04512-60060	WASHER, SPRING	RONDELLE GROWER	FEDERRING	2		
100	14971-1272-0	COVER, MUFFLER FLANGE	COUVERCLE	ABDECKUNG	1		
110	01053-50608	BOLT	VIS	BOLZEN	2		
120	04512-60060	WASHER, SPRING	RONDELLE GROWER	FEDERRING	2		

0800

GLOW LAMP AND TIMER
INDICATEUR DE PRECHAUFFAGE ET TEMPORISATEUR
GLOWLAMPE UND ZEITMESSER
(OPTION)

C01-L

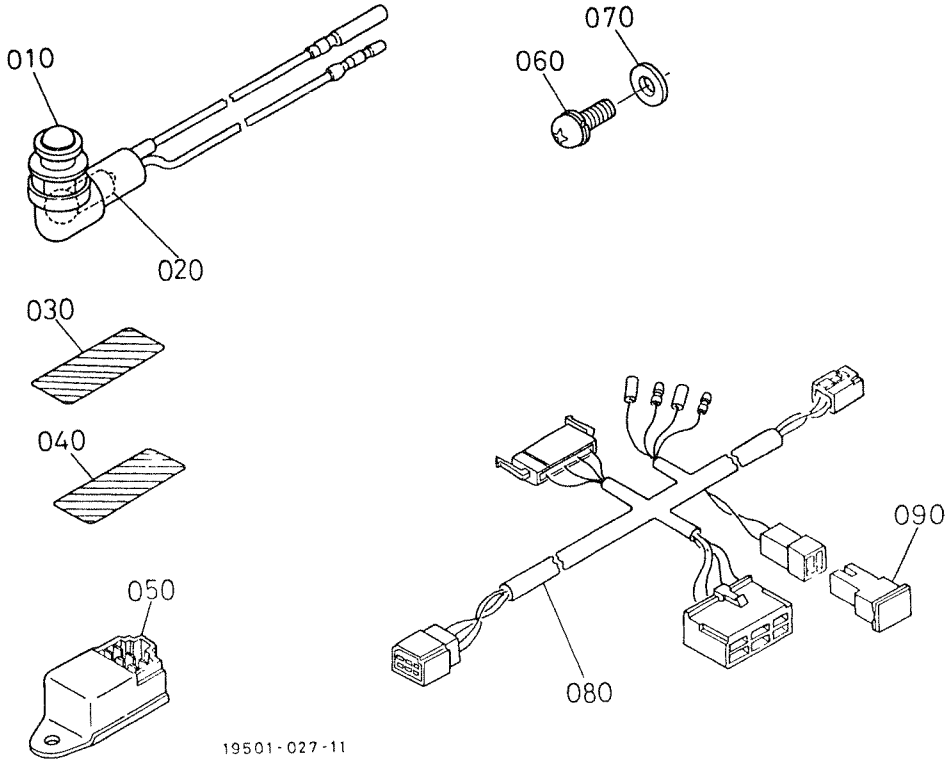

19501-027-11

A:EA300-ENB1-1

REF.No. POS.No. BILD-Nr.	PART No. REFERENCE BESTELL-Nr.	PART NAME	DESIGNATION	BEZEICHNUNG	Q' TY/S, No. Q' TE/No, S. STUECK/S. Nr.	I.C.	REMARKS REMARQUES BEMERKUNGEN
010	66711-5529-0	ASSY LAMP, OIL	ENS, KEROSENE	MAUTAGE OELLAMPE	A 2		
020	34150-3459-0	VALVE	SOUPAPE	VENTIL	4		
030	1G111-8834-0	LABEL, OIL LAMP	ETIQUETTE	AUFKLEBER	1		
040	1G111-8815-0	LABEL, GLOW LAMP	ETIQUETTE	AUFKLEBER	1		
050	15694-6599-0	TIMER, GLOW LAMP	TEMPORISATEUR	LAMPETREMBLEUR	1		
060	03004-50612	SCREW, WITH WASHER	VIS	SCHRAUBE	1		
070	04013-60060	WASHER, PLAIN	RONDELLE FREIN	SCHEIBE	1		
080	1G111-6582-0	WIRE HARNESS	HARNESS DE FIL	KABELGESCHIRR	1		
090	1G111-6572-0	FUSE	FUSIBLE	SICHERUNG	1		

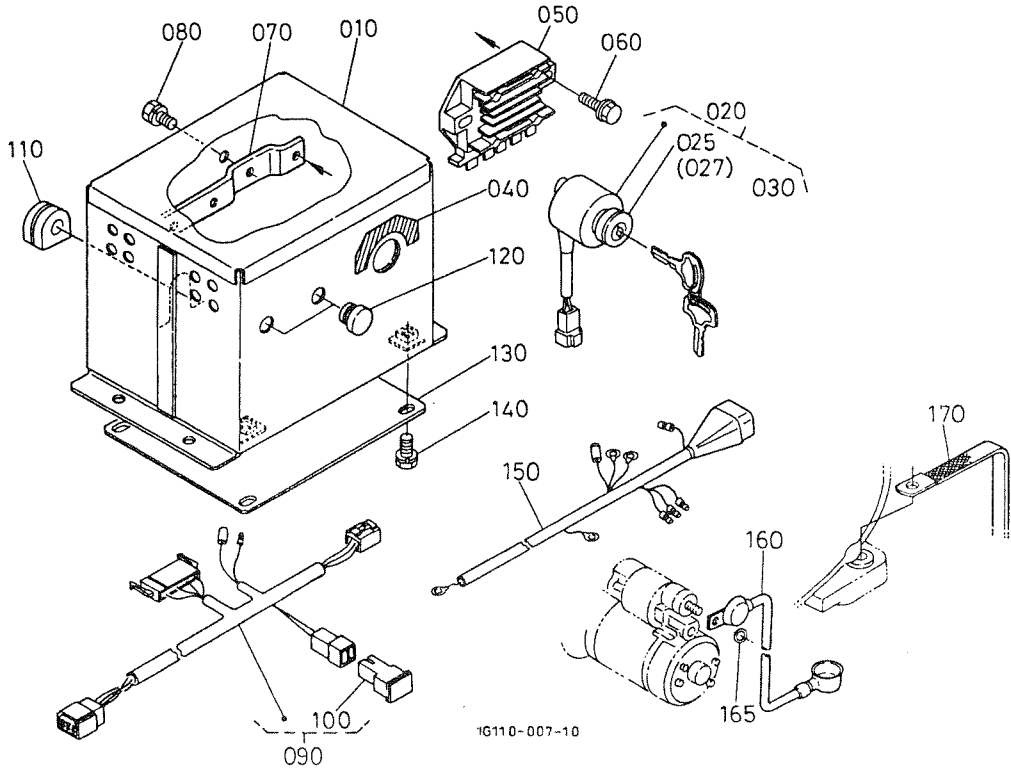

A:EA300-ENB1-1

REF.No POS.No BILD-Nr	PART No. REFERENCE BESTELL-Nr.	PART NAME	DESIGNATION	BEZEICHNUNG	Q' TY/S. No. Q' TE/No. S. STUECK/S. Nr.	I.C.	REMARKS REMARQUES BEMERKUNGEN
010	1G111-6364-0	BOX, SWITCH	BOITE, INTER RUPTEUR	ZUENDSCHALTERGITTER	A		
020	37410-5911-0	ASSY SWITCH, STARTER	ENS. INTERRUPTEUR	ANLASSERSCHALTER	1		
025	37410-5518-0	CAP, STARTER SWITCH	CAPUCHON, INTERRUPT.	ABDECKUNG, ANLASSER	1		
027	66416-5517-0	WASHER	RONDELLE	SCHEIBE	1		
030	37410-5515-0	KEY, STARTER	CLAVETTE DE DEMARRE.	KEL, ANLASSER	1		
040	11420-8752-0	LABEL, STARTER SWITCH	ETIQUETTE	AUFKLEBER	1		
050	11420-6460-0	ASSY REGULATOR	REGULATEUR	REGULATOR	1		
060	01754-50616	BOLT, FLANGE	VIS DE BUTEE	FLANSCHEN-BOLZEN	2		
070	1G111-6461-0	STAY, REGULATOR	SUPPORT REGULATEUR	TRAEGER	1		
080	01202-50610	BOLT	VIS	BOLZEN	2		
090	1G111-6581-0	WIRE HARNESS	HARNESS DE FIL	KABELGESCHIRR	1		
100	1G111-6572-0	FUSE	FUSIBLE	SICHERUNG	1		
110	14958-6585-0	GROMMET	GRUMMET	GUMMITUELLE	1		
120	14958-6587-0	CAP	BOUCHON	KAPPE	2		
130	1G111-6365-0	COVER, SWITCH, BOX	COUVERCLE	DECKEL	1		
140	01202-50610	BOLT	VIS	BOLZEN	4		
150	14279-6505-0	ASSY WIRE HARNESS	ENS. FAISC. DE FILS	GRP. KABELGESCHIRR	1		
160	15377-6556-0	CORD, BATTERY	CABLE BATTERIE	KABEL, BATTERIE	1		
165	04012-50080	WASHER, PLAIN	RONDELLE FREIN	SCHEIBE	1		
170	54266-4172-0	CORD, EARTH	CABLE DE TERRE	KABEL, ERDE	1		

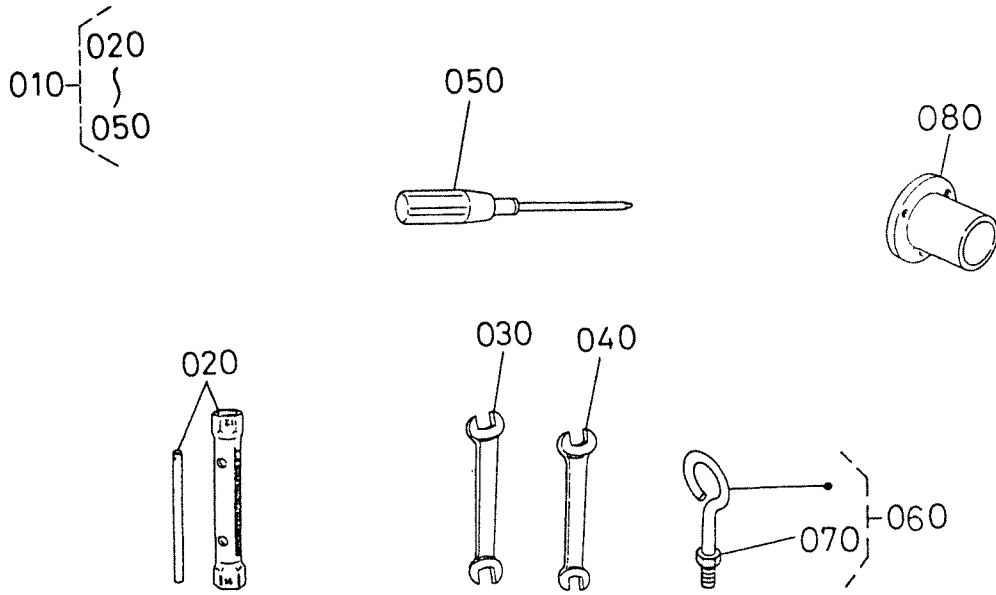

1G110-008-10

A:EA300-ENB1-1

REF.No. POS.No BILD-Nr	PART No. REFERENCE BESTELL-Nr.	PART NAME	DESIGNATION	BEZEICHNUNG	Q' TY/S. No. Q' TE/No. S. STUECK/S. Nr.	I.C.	REMARKS REMARQUES BEMERKUNGEN
					A		
010	11251-8601-0	ASSY TOOLS	ENS. OUTILS	MONTAGEWARKZUG			
020	14301-9137-0	SPANNER, BOX	CLEF A ECROUS	SPANNERKASTEN	1		
030	07012-11012	SPANNER	CLEF	SCHLUSSEL	1		
040	07012-11417	SPANNER	CLEF	SCHLUSSEL	1		
050	07115-56143	SCREWDRIVER, CROSS	TOURNEVIS CRUCIF.	SCHRAUBENKSTEN	1		
060	14972-0178-0	ASSY BOLT, HOOK ENGIN	ENS. BOULON	AUGENSCHRAUBE	1		OPTION
070	02114-50080	NUT	ECROU	MUTTER	1		OPTION
080	14972-8519-0	PULLEY, FLAT	POULIE, PLATE	SCHEIBE	1		OPTION

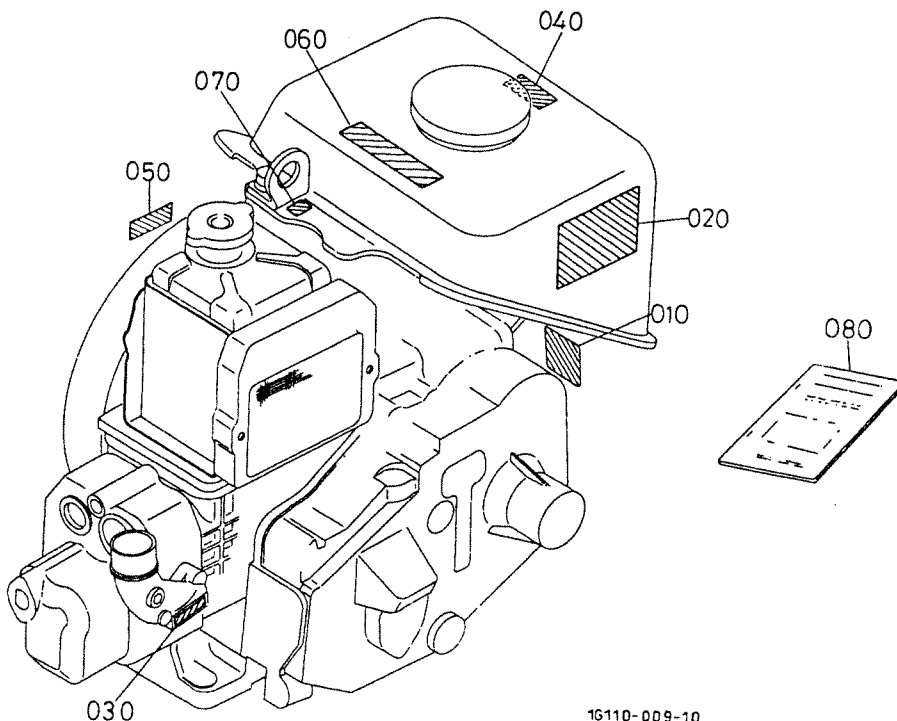

1G110-009-10

A:EA300-ENB1-1

REF.No. POS.No. BILD-Nr	PART No. REFERENCE BESTELL-Nr.	PART NAME	DESIGNATION	BEZEICHNUNG	Q'TY/S.No. Q'TE/No. S. STUECK/S. Nr.	I.C.	REMARKS REMARQUES BEMERKUNGEN
010	1G111-8811-0	NAME PLATE, ENGINE	PLAQUE MOTEUR	BEZEICHNUNGSTAFEL	A		
020	19151-8821-0	LABEL, CAUTION	ETIQUETTE	AUFKLEBER, ACHTUNG	1		
030	14433-6072-0	LABEL, STARTER	ETIQUETTE	AUFKLEBER	1		
040	11151-8719-0	LABEL, CORP/T. SYMBOL	ETIQUETTE	ETIKETTIEUNG	1		
050	14799-8822-0	LABEL, CAUTION	ETIQUETTE	AUFKLEBER, ACHTUNG	1		
060	11131-8741-0	LABEL, FUEL FILTER	ETIQUETTE	AUFKLEBER, KRAFTSTF.	1		
070	19187-8836-0	LABEL, ENGINE-HOOK	ETIQUETTE	AUFKLEBER	1		
080	19502-8915-7	MANUAL, INSTRUCTION	MANUEL D' INSTRUCTION	BETRIEBSANLEITUNG	1		

NUMERICAL INDEX
INDEX NUMERIQUE
NUMERISCHEN INDEX

D01-L

PART No. REFERENCE BESTELL-Nr	LOCATION No. No. D' EMBLACEMENT SUCH-Nr	PART No. REFERENCE BESTELL-Nr	LOCATION No. No. D' EMBLACEMENT SUCH-Nr	PART No. REFERENCE BESTELL-Nr	LOCATION No. No. D' EMBLACEMENT SUCH-Nr	PART No. REFERENCE BESTELL-Nr	LOCATION No. No. D' EMBLACEMENT SUCH-Nr
01023-50612	B02-L-160 B02-R-100 B04-R-030 B06-R-120 B08-L-040 B15-L-190	02056-50050	B02-R-080	07115-56143	C02-L-050	14279-7221-0	B14-L-130
01023-50614	B02-R-180 B06-R-070 B09-L-050	02056-50060	B05-L-070 B07-R-140	07715-01607	B03-L-050	14279-7401-0	B14-R-010
01023-50616	B04-R-060	02112-50080	B13-L-260	07715-03205	B09-L-150	14279-7410-0	B14-R-020
01023-50616	B05-R-080 B05-R-150 B08-L-030 B14-L-140 B14-R-110	02112-50120	B14-R-090	09550-25357	B05-R-190	14279-7411-0	B14-R-030
01023-50618	B12-R-030	02114-50080	B01-L-170 B16-R-040	10101-4239-0	B08-L-090	14301-3363-0	B01-L-030 B02-L-020
01023-50620	B14-L-100 B14-R-120	02116-50080	B09-R-090	11059-3227-0	B03-L-020	14301-3395-0	B01-L-070
01023-50622	B08-L-130 B12-L-110	02156-50080	B12-R-060	11131-7203-0	B14-L-020	14301-4236-0	B12-L-030
01023-50622	B16-L-130	02761-50040	B10-L-060	11131-8724-0	B14-L-025	14301-4357-0	B11-R-130
01023-50625	B01-L-140	02761-50040	B10-L-060	11151-5789-0	B09-R-010	14301-4359-0	B11-R-170
01023-50632	B16-L-140	03004-50612	C01-L-060	11151-6220-0	B05-R-160	14301-4365-0	B11-R-180
01023-50635	B01-L-130 B02-L-060	03004-50408	B02-L-100	11151-8719-0	C02-R-040	14301-6631-0	B02-R-110
01023-50665	B02-L-070	03024-50408	B02-L-100	11251-8601-0	C02-L-010	14301-9137-0	C02-L-020
01023-50680	B02-L-080	03024-50414	B13-L-240	11420-0501-2	B02-L-090	14311-6050-4	B08-L-070
01053-50512	B06-L-140	03024-50510	B02-L-120	11420-3543-0	B04-L-020	14311-6070-0	B08-L-010
01053-50608	B16-R-080 B16-R-110	03024-50514	B09-L-100	11420-3691-0	B03-L-070	14431-1243-0	B16-R-060
01053-50614	B07-L-090 B15-L-020	03410-50606	B15-R-090	11420-6460-0	C01-R-050	14433-6072-0	C02-R-030
01053-50660	B14-R-140	04012-50060	B09-L-030	11420-8752-0	C01-R-040	14541-7432-2	B15-L-060
01055-50625	B09-R-030	04012-50080	B07-R-160 B09-R-080	11982-6122-0	B04-R-070	14541-9685-0	B05-L-020
01055-50630	B09-R-050	04012-50080	B15-L-140 C01-R-165	12521-4103-0	B12-L-050	14595-0331-0	B01-R-100
01123-50820	B12-L-070	04013-60040	B10-L-070	12521-4134-0	B12-L-060	14595-0413-0	B02-L-050
01123-50830	B06-R-090	04013-60060	B07-R-150 C01-L-070	12545-4135-0	B12-L-040	14595-0472-0	B01-L-120
01123-50845	B11-R-190 B12-L-090	04013-60080	B12-L-080	14107-5134-0	B08-R-100	14595-0543-0	B02-L-130
01133-51030	B12-R-040	04512-60060	B02-R-150 B05-L-080	14107-6227-0	B05-R-180	14595-1223-0	B16-R-020
01202-50610	C01-R-080 C01-R-140	04512-60080	B01-L-180 B12-R-070	14109-5130-0	B08-R-150	14595-7245-0	B14-L-080
01202-50612	B04-R-080	04611-00500	B05-L-100	14111-4241-0	B11-R-050	14611-3609-0	B13-R-010
01222-50610	B07-R-080	04612 00160	B05-R-220	14274-7206-0	B14-L-010	14611-5120-0	B08-R-080
01513-50816	B16-R-030	04724-00100	B09-L-120 B13-R-030	14278-2501-7	B06-R-010	14799-8822-0	C02-R-050
01518-50616	B14-L-040	04724-00160	B03-L-080	14278-6301-0	B12-R-010 B13-L-010	14911-1146-0	B16-L-050
01518-50620	B05-L-060	04811-00070	B07-R-110	14278-6303-0	B13-L-050	14911-1153-0	B16-L-090
01754-50612	B04-L-040	04811-00080	B01-L-080	14278-6304-0	B13-L-040	14911-1192-0	B16-L-080
01754-50614	B08-L-160	04811-11050	B05-L-040	14278-6305-0	B13-L-130	14911-1241-2	B16-R-050
01754-50616	C01-R-060	04811-50300	B03-L-040	14278-6307-0	B13-L-030	14911-1247-0	B16-R-070
01754-50618	B14-L-090	05012-00612	B01-L-040	14278-6308-0	B13-L-020	14911-2629-0	B07-L-030
01754-50620	B05-L-050	05012-00614	B12-R-050	14278-6308-0	B13-L-020	14911-3211-0	B03-L-010
01820-50635	B14-L-120	05122-50816	B15-L-130	14278-6311-0	B13-L-025	14911-3540-0	B04-L-010
02012-60060	B07-R-130	05411-00412	B01-L-050	14278-6318-0	B13-L-220	14911-3545-0	B04-L-030 B05-L-030
02014-50060	B02-R-140 B09-R-040 B14-L-050 B15-L-170	05411-00612	B01-R-040	14278-6319-0	B13-L-210	14911-3695-0	B03-L-060
02052-50080	B15-L-090	05511-50215	B15-L-150	14278-6320-0	B13-L-080	14911-3695-0	B03-L-060
02054-50040	B02-L-110	05712-00510	B05-R-210	14278-6325-0	B13-L-090	14911-4275-0	B02-L-200
		05712-00515	B06-L-160	14278-6332-0	B13-L-230	14911-4275-0	B11-R-020 B11-R-040
		05712-00518	B07-L-070	14278-6338-0	B13-L-110	14911-4301-4	B11-R-100
		06311-75022	B01-R-020	14278-6339-0	B13-L-120	14911-4351-3	B11-R-110
		06331-35010	B09-L-110	14278-6345-0	B13-L-150	14911-5105-0	B08-R-030
		07012-11012	C02-L-030	14278-6351-0	B13-L-190	14911-5106-0	B08-R-020
		07012-11417	C02-L-040	14278-6352-0	B13-L-200	14911-5132-0	B08-R-090
				14278-6359-3	B12-R-020	14911-5143-0	B08-R-180
				14278-9201-0	B13-L-250	14911-5528-0	B09-L-020
				14278-9401-0	B13-L-160	14911-5531-0	B09-L-060
				14278-9616-0	B13-L-070	14911-5648-0	B09-L-140
				14279-0174-0	B14-L-150	14911-7477-0	B15-L-080
				14279-2533-5	B06-R-060	14911-9493-0	B01-L-060
				14279-4101-8	B12-L-010	14911-9685-0	B01-R-030
				14279-4113-2	B12-L-100	14913-5766-0	B09-R-060
				14279-4171-0	B12-L-020	14913-5767-0	B09-R-070
				14279-4201-0	B11-R-010	14941-2324-0	B06-L-100
				14279-4220-0	B11-R-060	14958-6585-0	C01-R-110
				14279-4250-0	B11-R-080	14958-6587-0	C01-R-120
				14279-428-0	B08-L-050	14971-0101-3	B01-L-010
				14279 6505-0	C01-R-150		

NUMERICAL INDEX
INDEX NUMERIQUE
NUMERISCHEN INDEX

D01-R

PART No. REFERENCE BESTELL-Nr	LOCATION No. No. D' EMLACEMENT SUCH-Nr	PART No. REFERENCE BESTELL-Nr	LOCATION No. No. D' EMLACEMENT SUCH-Nr	PART No. REFERENCE BESTELL-Nr	LOCATION No. NO. D' EMLACEMENT SUCH-Nr	PART No. REFERENCE BESTELL-Nr	LOCATION No. No. D' EMLACEMENT SUCH-Nr
14971-0231-0	B01-L-090	14971-5614-0	B09-L-090	15261-2198-0	B06-L-060	15841-9869-0	B10-R-110
14971-0235-0	B01-L-100	14971-5641-0	B09-L-130	15261-2432-0	B05-R-130	15841-9870-0	B11-L-110
14971-0341-2	B01-R-070	14971-5704-0	B07-R-070	15261-2436-0	B05-R-110	15841-9871-0	B11-L-110
14971-0471-0	B01-L-110	14971-5723-0	B07-R-090	15261-2437-0	B05-R-120	15841-9872-0	B11-L-110
14971-0537-0	B02-L-150	14971-6090-0	B08-L-080	15261-2498-0	B05-R-100	15841-9873-0	B11-L-110
14971-0538-0	B02-L-190	14971-6128-4	B04-R-050	15261-5422-0	B07-R-030	15841-9874-0	B11-L-110
14971-0547-0	B02-L-140	14971-6212-0	B05-R-200	15261-6635-0	B02-R-070	15841-9875-0	B11-L-110
14971-0555-2	B02-L-040	14971-6621-0	B02-R-130	15261-6663-0	B02-R-160	15841-9876-0	B11-L-110
14971-0622-0	B01-L-150	14971-6629-0	B02-L-030	15261-9201-0	B15-R-110	15841-9877-0	B11-L-110
14971-1101-2	B16-L-010	14971-6632-2	B02-R-060	15261-9401-0	B15-R-120	15841-9878-0	B11-L-110
14971-1105-0	B16-L-030	14971-6655-2	B02-R-090	15261-9501-0	B07-R-100	15841-9879-0	B11-L-110
14971-1110-0	B16-L-070	14971-7212-0	B14-L-030	15263-5738-0	B07-R-120	15841-9880-0	B11-L-110
14971-1117-0	B16-L-060	14971-7214-0	B14-L-070	15263-6664-0	B02-R-170	15841-9881-0	B11-L-110
14971-1118-0	B16-L-020	14971-7225-0	B14-L-110	15271-1403-0	B15-R-130	15841-9882-0	B11-L-110
14971-1152-0	B16-L-040	14971-7412-0	B14-R-130	15271-1624-0	B05-R-060	15841-9883-0	B11-L-110
14971-1161-4	B16-L-110	14971-7428-0	B15-L-010	15271-5122-0	B08-R-050	15841-9884-0	B11-L-110
14971-1165-0	B16-L-120	14971-7430-2	B15-L-050	15272-6757-0	B02-L-180	15841-9885-0	B11-L-110
14971-1211-2	B16-R-010	14971-7436-2	B15-L-120		B11-R-200	15841-9886-0	B11-L-110
14971-1272-0	B16-R-100	14971-7441-0	B15-L-070	15321-6325-0	B13-L-180	15841-9887-0	B11-L-110
14971-1405-0	B15-R-070	14971-7495-2	B15-L-180	15377-6556-0	C01-R-160	15841-9888-0	B11-L-110
14971-1406-0	B15-R-080	14971-8845-0	B16-L-100	15381-2214-0	B06-L-070	15841-9889-0	B11-L-110
14971-1451-2	B02-R-010	14971-9115-0	B01-L-160	15393-4310-0	B11-R-140	15841-9890-0	B11-L-110
14971-1452-0	B02-R-020	14971-9131-0	B15-L-110	15393-4358-0	B11-R-150	15841-9891-0	B11-L-110
14971-1511-0	B05-R-020	14971-9501-2	B06-R-030	15531-2105-0	B06-L-020	15841-9892-0	B11-L-110
14971-1601-0	B05-R-030	14971-9701-0	B15-L-040	15531-2109-0	B06-L-020	15852-3314-0	B03-L-030
14971-1615-0	B05-R-040	14972-0178-0	C02-L-060	15531-2191-0	B06-L-010	16221-5442-0	B09-R-020
14971-1627-0	B05-R-070	14972-1311-0	B15-R-010	15532-2111-0	B06-L-010	16241-1328-0	B15-R-060
14971-1651-0	B05-R-050	14972-1312-0	B15-R-020	15694-2201-0	B06-L-050	16241-1333-0	B15-R-040
14971-2301-2	B06-L-090	14972-5654-0	B07-R-060	15694-2231-0	B06-L-080	16241-1354-0	B01-R-050
14971-2336-0	B06-R-040	14972-7414-0	B14-R-040	15694-2297-0	B06-L-080	16241-1356-0	B01-R-060
14971-2337-2	B06-R-050	14972-7415-0	B14-R-080	15694-2298-0	B06-L-080	16261-1555-0	B05-R-010
14971-2345-0	B06-L-110	14972-7417-0	B14-R-050	15694-6599-0	C01-L-050	16261-6382-2	B06-R-020
14971-2355-0	B05-L-090	14972-7424-0	B14-R-070	15841-5316-0	B10-R-060	16475-5328-0	B10-R-070
14971-2359-0	B06-L-130	14972-7425-0	B14-R-060	15841-5317-0	B10-R-040	16851-6551-0	B10-L-050
14971-2401-0	B05-R-090	14972-8519-0	C02-L-080	15841-5323-0	B10-R-030	16873-8843-0	B11-R-160
14971-2411-0	B06-L-150	14981-0404-2	B05-L-010		B10-R-110	17016-6325-0	B13-L-060
14971-2425-0	B05-R-140	14981-2346-0	B06-L-120	15841-5335-0	B10-R-050	19077-5365-0	B10-L-030
14971-2531-2	B06-R-110	15109-3366-0	B07-R-040	15841-5361-0	B10-R-090	19090-1539-0	B09-L-040
14971-2625-0	B07-L-010	15221-5103-0	B08-R-040	15841-5362-2	B10-L-020	19104-6111-2	B04-R-040
14971-2628-0	B07-L-020	15221-5107-0	B08-R-160	15841-9203-0	B10-R-020	19142-9501-0	B06-R-100
14971-2644-0	B07-L-040	15221-5123-0	B08-R-060	15841-9404-0	B10-R-080	19151-8821-0	C02-R-020
14971-2645-0	B07-L-050	15221-5124-0	B08-R-070	15841-9810-0	B10-R-100	19187-8836-0	C02-R-070
14971-2646-0	B07-L-060	15221-5125-0	B08-R-170	15841-9851-0	B10-R-110	19215-0351-2	B01-R-080
14971-2671-0	B01-L-020	15221-5127-0	B08-R-120	15841-9852-0	B10-R-110	19501-8451-0	B06-R-080
14971-2681-0	B07-L-080	15221-5128-0	B08-R-130	15841-9853-0	B10-R-110	19502-8915-7	C02-R-080
14971-3575-0	B05-L-110	15221-5129-0	B08-R-140	15841-9854-0	B10-R-110	19701-7494-0	B15-L-160
14971-3577-0	B05-L-120	15221-5138-2	B08-R-110	15841-9855-0	B10-R-110	19701-9685-0	B02-R-120
14971-3611-2	B13-R-020	15221-9482-0	B13-L-170	15841-9856-0	B10-R-110	1G111-0300-2	B01-R-010
14971-3641-0	B03-R-010	15231-4356-0	B11-R-120	15841-9857-0	B10-R-110	1G111-0402-3	B02-L-010
14971-4202-0	B02-L-170	15231-6302-2	B13-L-140	15841-9858-0	B10-R-110	1G111-0480-0	B04-R-010
14971-4202-0	B11-R-030	15261-1324-0	B15-R-030	15841-9859-0	B10-R-110	1G111-5101-2	B08-L-120
14971-4275-0	B08-L-060	15261-1336-0	B15-R-050	15841-9860-0	B10-R-110		B08-R-010
	B11-R-070	15261-1423-2	B15-R-140	15841-9861-0	B10-R-110	1G111-5211-0	B08-L-100
	B11-R-090	15261-1424-0	B15-R-150	15841-9862-0	B10-R-110	1G111-5300-0	B10-L-010
14971-4292-2	B08-L-020	15261-1441-0	B15-R-100	15841-9863-0	B10-R-110		B10-R-010
14971-5211-0	B08-L-100	15261-1462-0	B02-R-030	15841-9864-0	B10-R-110	1G111-5371-2	B08-L-140
14971-5212-0	B08-L-110	15261-1463-0	B02-R-050	15841-9865-0	B10-R-110	1G111-5402-0	B07-R-010
14971-5385-2	B08-L-150	15261-1464-0	B02-R-040	15841-9866-0	B10-R-110	1G111-6364-0	C01-R-010
14971-5505-2	B09-L-010	15261-2131-0	B06-L-030	15841-9867-0	B10-R-110	1G111-6365-0	C01-R-130
14971-5604-0	B09-L-070	15261-2133-0	B06-L-040	15841-9868-0	B10-R-110	1G111-6461-0	C01-R-070

NUMERICAL INDEX
INDEX NUMERIQUE
NUMERISCHEN INDEX

D02-L

PART No. REFERENCE BESTELL-Nr	LOCATION No. No. d' EMBLACEMENT SUCH-Nr	PART No. REFERENCE BESTELL-Nr	LOCATION No. No. d' EMBLACEMENT SUCH-Nr	PART No. REFERENCE BESTELL-Nr	LOCATION No. No. d' EMBLACEMENT SUCH-Nr	PART No. REFERENCE BESTELL-Nr	LOCATION No. No. d' EMBLACEMENT SUCH-Nr
1G111-6572-0	C01-L 090 C01-R 100						
1G111-6581-0	C01-R 090						
1G111-6582-0	C01-L 080						
1G111-8811-0	C02-R 010						
1G111-8815-0	C01-L 040						
1G111-8834-0	C01-L 030						
1G111-8855-0	B04-R 020						
1G111-9568-0	B10-L 040						
1G121-5429-0	B07-R 050						
1T251-7311-0	B01-R 110						
34150-3459-0	C01-L 020						
37410-5515-0	C01-R 030						
37410-5518-0	C01-R 025						
37410-5911-0	C01-R 020						
54266-4172-0	C01-R 170						
66416-5517-0	C01-R 027						
66711-5529-0	C01-L 010						

PIES. No.		EDA0000678
BLOCK No.	No. / LINE	A(1)
01	01	1G110-00000 EA300-ENB1-1

KS. NA×AK. 0. AK

KUBOTA

THE BASIC NECESSITIES GIANT

"Technology for the Needs of Tomorrow" is the ambition of everyone at Kubota. Through research and the development of new products for agriculture, industry, construction, and many other areas of modern life, we at Kubota hope to realize this goal.

GEANT DES NECESSITES FONDAMENTALES

"La Technologie pour les Besoins de Demain" est l'ambition de chacun CHEZ KUBOTA. A travers la recherche et le développement de nouveaux produits pour l'Agriculture, l'Industrie, la Construction et plusieurs autres domaines de la vie moderne, Nous KUBOTA, espérons atteindre ce but.

GIGANT DER FUNDAMENTALEN NOTWENDIGKEITEN

"Technologie für die Welt von Morgen"
Wir bei KUBOTA arbeiten ständig an diesem Ziel durch Forschung und Entwicklung neuer Produkte für den Agrarsektor, die Industrie, die Bauwirtschaft und viele andere Bereiche unserer modernen Zeit. Die Ziellinie verschiebt sich ständig, aber wir kommen ihr näher.

PRINTED in JAPAN
IMPRIME Au JAPON
DRUCK JAPAN